

# OPERATING MANUAL



English



English



**ALADIN<sup>®</sup> AIR 2 O<sub>2</sub>**

SWISS MADE BY UWATEC AG

# Operating scheme for surface functions



B and E



B and +



B and -

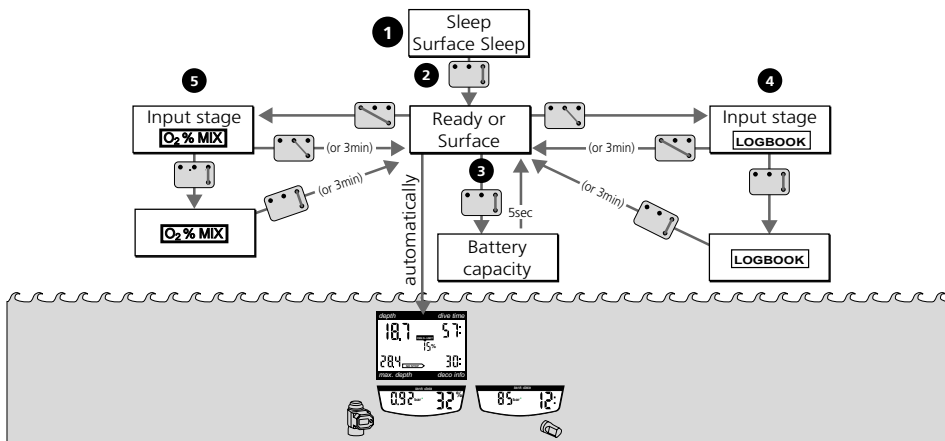

## Important remarks concerning signal words and symbols

This operating manual makes use of the following icons to indicate especially important comments:

### Remarks:



Informations and tips which are important for optimal use of the functions of your Aladin® Air Z O<sub>2</sub>.

### Attention:



Informations and tips which are important for optimal use of the functions of your Aladin® Air Z O<sub>2</sub>.

### Danger!



Indicates a potentially hazardous situation which, if not avoided, could result in death or serious injury.

The following symbols are used in the operating manual:



Flashing display



Acoustic alarm signal



Operating instruction for manual input  
Example: bridging contacts B and E

B



Only valid if an Oxy2 is used



Only valid if a pressure transmitter is used

January 2000, Copyright by Uwatec Switzerland

## Safety considerations

You must carefully read and understand this entire manual before using your Aladin® Air Z O<sub>2</sub>.



Diving has many inherent risks. Even if you follow the instructions of this manual in a careful manner, it is still possible that you may be seriously injured or die from decompression sickness, oxygen toxicity or some other inherent risk of scuba Nitrox or compressed air. Unless you are fully aware of these risks and are willing to personally accept and assume responsibility for those risks, do not use the Aladin® Air Z O<sub>2</sub>!

The Aladin® Air Z O<sub>2</sub> is a decompression tool to assist a trained and certified diver in making decisions (there is no dive planner available in the Air Z O<sub>2</sub>). As with any tool, the Aladin® Air Z O<sub>2</sub> may be misused if the following safety and operational precautions are not strictly followed. If they are followed, careful use of the Aladin® Air Z O<sub>2</sub> can increase your diving enjoyment and reduce your risk of decompression sickness. If they are not, you will be placing yourself at serious risk for decompression sickness.

While the Aladin® Air Z O<sub>2</sub> is a technically advanced tool based on mathematical models of decompression sickness and oxygen toxicity, neither it nor any other diving computer (or table) can actually monitor the physiological changes that occur in your body as you dive. In addition, each diver will vary in his or her susceptibility to decompression sickness. In addition, each diver will vary in his or her susceptibility to decompression sickness and each individual diver's own susceptibility may vary from day to day. Combined with the fact that decompression modelling is an inexact science, and must be based to some extent on certain unproven assumptions, it is emphasis on you, the individual diver, to dive responsibly and to carefully follow all standard safe diving practices as well as the recommendations contained in this manual.

### Guidelines for the use of Aladin® Air Z O<sub>2</sub>:

The following guidelines for using Aladin® Air Z O<sub>2</sub> are derived from the latest medical research for diving with diving computers. Following these guidelines will greatly increase your safety while diving, but cannot guarantee that decompression sickness will not occur.

- The Aladin® Air Z O<sub>2</sub> is designed for dives with nitrox (max.99 %O<sub>2</sub>)and compressed air (21%O<sub>2</sub>) only. Do not use the Aladin® Air Z O<sub>2</sub> for dives made with other mixed gases.
- It is essential to check the set mixture or O<sub>2</sub> fraction before each dive and to compare it to the gas mixture to be used, even if you are using an Oxy2. Always remember: Setting a wrong mixture causes eit-

## Safety considerations

- her insufficient decompression calculations or a too low calculation of the oxygen-toxicity!
- Always check the diving limits considering the oxygen content and standard sports diving procedures (decompression sickness, oxygen toxicity).
  - Do not dive deeper than 40 metres.
  - The danger of nitrogen narcosis has to be taken into consideration for all dives regardless of the gas mixture. The Aladin® Air Z O<sub>2</sub> gives no warning about this.
  - On all dives with the Aladin® Air Z O<sub>2</sub>, make a safety stop for at least one to three minutes within the 3 to 5 metre zone.
  - Always make the deepest dive of the day first when repetitive dives are planned, and for each dive make sure that the deepest portion of that dive is done at the beginning of the dive.
  - If your diving cylinder is equipped with a reserve or "J"-type valve, make certain that the reserve function is in an open (down) position. Failure to keep the reserve open will result in the improper calculation of the dive data which depends on tank pressure.
  - All divers using dive computers to plan dives and indicate or determine decompression status must use their own computer which they take with them on all dives.
  - If the Aladin® Air Z O<sub>2</sub> fails at any time during the dive, the dive must be terminated, and appropriate surfacing procedures should be initiated immediately.
  - On any given dive, all divers in a buddy group must follow the most conservative dive computer for that particular dive.
  - Repetitive dives after exchanging the dive computer: Wait at least 24 hour before you start with the repetitive dive.
  - You **MUST** be familiar with all signs and symptoms of decompression sickness before using the Aladin® Air Z O<sub>2</sub>! Seek **IMMEDIATE** treatment for decompression sickness should any of these signs or symptoms occur after a dive! There is a direct correlation between the effectiveness of treatment and the delay between the onset of symptoms and the treatment for decompression sickness.
  - Always observe the optical and acoustic alarm signals of the Aladin® Air Z O<sub>2</sub>. Avoid situations of increased risk which are marked with a warning sign in this operating manual.
  - If the ascent arrow appears in the lower display window, start ascending.
  - If the flashing ascent arrow appears in the lower display window, start to ascend immediately.
  - See also page 10, 74-76, 100.

## Aladin® Air Z O<sub>2</sub> – The Diving System

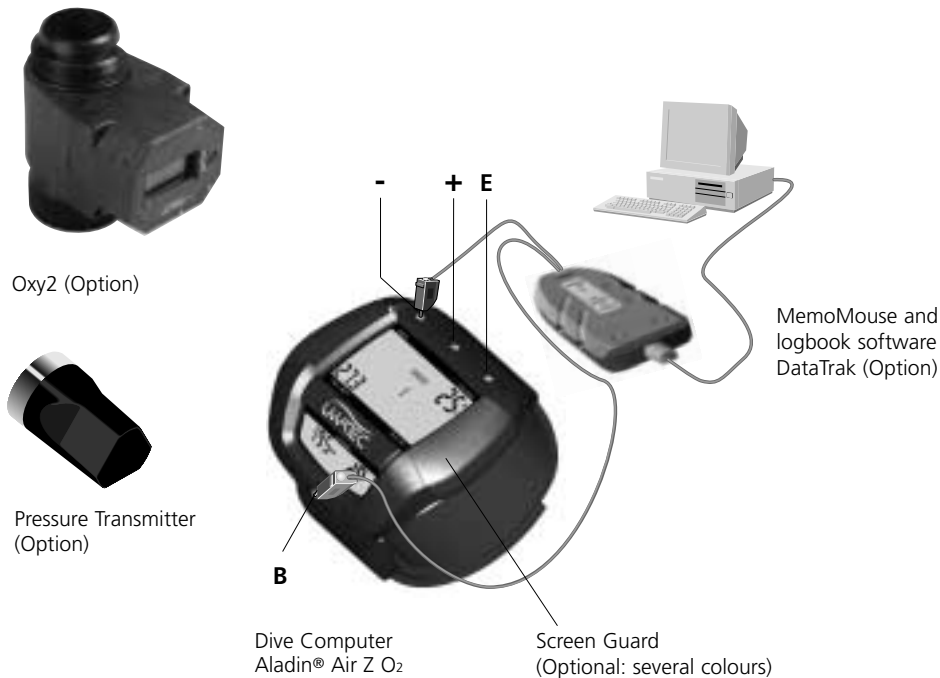

## List of chapters

<b>I</b>	<b>Aladin® Air Z O<sub>2</sub> – Introduction</b>	<b>9</b>		
1	Aladin® Air Z O <sub>2</sub> – Introduction	10		
2	Aladin® Air Z O <sub>2</sub> – More Safety in Diving	10		
3	Aladin® Air Z O <sub>2</sub> – Your Personal Companion	13		
4	The Calculation Model ZH-L8 ADT			
	4.1 Description	14		
	4.2 Advantages	16		
5	Safety in Diving	16		
<b>II</b>	<b>Aladin® Air Z O<sub>2</sub> – The System</b>	<b>17</b>		
1	Description			
	1.1 Structure	18		
	1.2 Reliability of transmission	19		
2	Pressure transmitter and Oxy2			
	2.1 Pressure transmitter operating modes and functions	20		
	2.2 Oxy2 operating modes and functions	21		
	2.3 Data transmission and reception	22		
3	Dive Computer			
	3.1 Operation	23		
	Active backlight	24		
	3.2 Operating modes	29		
4	Setting Up (Oxy2, press. transmitter and Aladin® Air Z O <sub>2</sub> )			
	4.1 Fitting the Oxy2 to a rebreather	34		
	4.2 Fitting of pressure transmitter	35		
	4.3 Remarks about pairing	37		
	4.4 How to check that the computer is paired correctly	38		
	4.5 Pairing of Oxy2 and dive computer	38		
	4.6 Pairing of press. transmitter and dive comp.	40		
<b>III</b>	<b>Diving with Aladin® Air Z O<sub>2</sub></b>	<b>41</b>		
1	Terminology/Symbols			
	1.1 Deco data during no-stop phase	42		
	1.2 Display during decompression phase	43		
	1.3 Indications on the lower display	43		
	1.4 Nitrox information	44		
2	Attention Messages and Alarms			
	2.1 Attention Messages	46		
	2.2 Alarms	49		
	2.3 Alarm low battery	51		
3	Preparation for a Dive			
	3.1 Preparation for a Dive with Oxy2	51		
	3.2 Preparation for a Dive with press. transm.	53		
	3.3 Setting the gas mixture	54		
4	Functions during the Dive			
	4.1 Dive time	55		
	4.2 Current depth	56		
	4.3 Maximum depth	56		
	4.4 Ascent rate	57		
	4.5 Partial pressure of oxygen (ppO <sub>2</sub> )	59		
	4.6 Oxygen toxicity (CNS O <sub>2</sub> %)	59		
	4.7 Oxygen fraction of the inspired gas mixture	61		
	4.8 Decompression information	61		
	4.9 Tank pressure 	63		
	4.10 Increased workload warning	64		
	4.11 Interruption of transmission	65		

## List of chapters

4.12 Remaining Bottom Time RBT 	65	<b>VI Trouble Shooting</b>	<b>91</b>
5 Functions at the Surface		1 Trouble Shooting	92
5.1 End of a dive	67	<b>VIII Appendix</b>	<b>95</b>
5.2 Desaturation time	68	1 Maintenance	96
5.3 No fly time	68	2 Technical Information	97
5.4 Warning of bubbles	69	3 Conversion of tank pressure	98
6 Diving in Mountain Lakes	70	4 Warranty	
		3.1 Recognition of warranty	99
		3.2 Scope of the warranty	99
		3.3 Warranty period and claim	99
		5 Safety considerations	100
		6 Serial No. / Dealer address	102
<b>IV Diving at Reduced Risk with Aladin® Air Z O<sub>2</sub></b>	<b>73</b>	<b>IX Index</b>	<b>103</b>
1 Diving at reduced risk with Aladin® Air Z O <sub>2</sub>			
1.1 Diving at reduced risk	74		
1.2 Diving at reduced risk for the first dive	74		
1.3 Minimizing risk on repetitive dives	75		
1.4 Response in increased risk situations	76		
<b>V Logbook</b>	<b>81</b>		
1 Survey	82		
2 Selection and Activation	83		
3 Selection of Dive	84		
4 Leaving the Logbook-Mode	85		
5 Output on PC	86		
<b>VI Communication Software for Windows®</b>	<b>87</b>		
1 MemoMouse, DataTrak and DataTalk			
1.1 Personal programming of the dive computer (DataTalk)	88		
1.2 Analysis and storage of real dives (DataTrak)	89		
1.3 Updates (DataTrak, DataTalk)	89		

## I Introduction

1	Aladin® Air Z O <sub>2</sub> – Introduction	10
2	Aladin® Air Z O <sub>2</sub> – More Safety in Diving	10
3	Aladin® Air Z O <sub>2</sub> – Your Personal Companion	13
4	The Calculation Model ZH-L8 ADT	4.1 Description 14 4.2 Advantages 16
5	Safety in Diving	16

## 1 Aladin® Air Z O<sub>2</sub> – Introduction

When you dive with an SCR with Oxy2 and Aladin® Air Z O<sub>2</sub> you will know your exact decompression, CNS clock status, Oxygen fractions and ppO<sub>2</sub> on line and in real time. With Aladin® Air Z O<sub>2</sub> paired to a pressure transmitter or Oxy<sub>2</sub> you dive more safely than ever before, though you can make more of your diving time thanks to the exact calculation of the gas-supply. In addition, Aladin® Air Z O<sub>2</sub> offers an unmatched comfort in carrying and operation. Aladin® Air Z O<sub>2</sub> gives you increased safety due to its calculation model. All the information necessary for safe diving are combined in one instrument.

With the Aladin® Air Z O<sub>2</sub> you are – due to its multi-function – ready for the future.

The Aladin® Air Z O<sub>2</sub> can increase both your diving pleasure and safety by reducing your risk of decompression sickness provided you carefully follow the instructions and guidelines given you in this manual. Unlike previous diving computers, which only base their decompression information on depth and time data, the Aladin® Air Z O<sub>2</sub> also considers temperature and diver workload, which are known to be additional risk factors for decompression sickness. By considering these risk factors as well as monitoring your exact supply, the Aladin® Air Z O<sub>2</sub> allows you to plan and execute dives with a greater degree of safety than with previous models of decompression computers.



The Aladin® Air Z O<sub>2</sub> and the Oxy2 are not to be used with closed circuit rebreathers.

Please read this operating manual carefully and to the last page.

If you are using an Oxy2, you must also carefully read the Oxy2 manual.

## 2 Aladin® Air Z O<sub>2</sub> – More Safety in Diving

Nitrox is a gas mixture consisting of nitrogen and oxygen. The kind of air used for diving with compressed air is the same as the normal air of the earth's atmosphere (78% nitrogen, 21% oxygen and 1% inert gases). Therefore, normal air is also Nitrox!

When talking of Nitrox as the breathing gas for diving, it describes a mixture with a higher percentage of oxygen. A higher percentage of oxygen (and automatically the reduction of nitrogen) has the advantage of lengthening the no-stop phase (or reducing the decompression phase), since less nitrogen is dissolved in the diver's body during the dive.

## 2 Aladin® Air Z O<sub>2</sub> – More Safety in Diving



The higher share of oxygen in the Nitrox-mixture also causes additional physiological problems by the toxic effects at a higher partial pressure of oxygen (ppO<sub>2</sub>). When breathing oxygen at a higher partial pressure, two kinds of oxygen toxicity can occur:

- CNS damages:  
Symptoms of poisoning occurring at short notice in the central nervous system (CNS). Such symptoms are: irritations of the respiratory organs, sickness, headache, pulmonary oedema, cramps, unconsciousness. The symptoms occur at a ppO<sub>2</sub> of more than 1 bar and depend on the term of exposure and on the partial pressure of oxygen.
- Damages of the lungs:  
Symptoms of pulmonary poisoning occurring in the long run. The symptoms occur at a ppO<sub>2</sub> from 0.5 bar and higher and with terms of exposure in the range of hours/days.

Aladin® Air Z O<sub>2</sub> considers the short term toxic effect of oxygen (CNS damages) by means of the so called „oxygen-clock“. It is based on a list which shows the units of toxicity for oxygen per unit of time and is dependent on the ppO<sub>2</sub>. The indication of toxicity is shown as „CNS O<sub>2</sub>%“ (= relative toxicity of oxygen for the central nervous system). CNS O<sub>2</sub> LIMIT=0% corresponds to the normal state before the first dive, and CNS O<sub>2</sub> LIMIT=100% corresponds to the critical upper limit. The list, initially published by the US Navy, is nowadays known by the name NOAA-list. We modified this list for the use with Aladin® Air Z O<sub>2</sub> in cooperation with Dr. Bill Hamilton, Hamilton Research Ltd. (Tarrytown, NY), a well-known specialist. The long term kind of oxygen poisoning has practically no relevance for diving with independent diving equipment and is therefore not considered in the design of Aladin® Air Z O<sub>2</sub>.





If nitrox is used for diving profound additional training is needed because of the physiological peculiarities of oxygen and the changing decompression due to the reduced percentage of nitrogen. Additional technical problems with the use and the maintenance of parts of the equipment are additional potential dangers when diving with nitrox or rebreathers. Therefore, we recommend strict adherence to the following guidelines and warnings.



1. Only dive with nitrox or SCR if you have been trained thoroughly by a recognised agency.
2.  Only use the pressure transmitter with open breathing systems. Aladin® Air Z O<sub>2</sub> must be set for a determined gas mixture. In partially-open and in closed circulation-systems, the gas mixture in the breathing loop can vary considerably from the mixture in the tank(s).
3. For dives with an SCR always use an Oxy2.
4.  Aladin® Air Z O<sub>2</sub> when used with Oxy2 does not show the tank pressure nor related warnings. Check the pressure gauge frequently.
5. Only use Aladin® Air Z O<sub>2</sub> for diving with an independent breathing apparatus. Aladin® Air Z O<sub>2</sub> is not designed for long-term exposures with Nitrox.
6.  If a pressure transmitter is used the Aladin® Air Z O<sub>2</sub> always calculates based on the gas mixture set by the user. Before each dive it is essential to check that this mixture setting is correct for the actual gas mixture to be used. Maximum deviation from the mixture calculation must not exceed 1% O<sub>2</sub>. A wrong gas mixture can be lethal!
7. Aladin® Air Z O<sub>2</sub> has a ppO<sub>2</sub>-warning, the default-limits of which are set at 1.5 bar ppO<sub>2</sub> max. This limit can be adjusted via MemoMouse/Data Talk in the range of 1.2 to 1.95 bar. An alternation of the ppO<sub>2</sub> max to higher than 1.6 bar is risky and is not recommended.
8. Frequently check the „oxygen-clock“ (CNS O<sub>2</sub>%), especially when the ppO<sub>2</sub> is greater than 1.5 bar. Finish the dive if the CNS O<sub>2</sub>% exceeds 75%.
9. Make sure you have a sufficiently long surface interval, just as when diving with compressed air. Oxygen also needs sufficient time to leave the body. Go on the next dive only when the CNS O<sub>2</sub>% has dropped below 40%.
10. Aladin® Air Z O<sub>2</sub> is a personal instrument like any other diving computer. This still applies when diving with compressed air (21% oxygen) between two nitrox-dives. Aladin® Air Z O<sub>2</sub> can be adjusted to compressed air and then also includes the calculation of the CNS O<sub>2</sub>% in the same way as with any other nitrox-dive.
11. Always remember: setting a wrong mixture causes either insufficient decompression calculations or a too low calculation of the oxygen-toxicity!

### 3 Aladin® Air Z O<sub>2</sub> – Your Personal Companion

Aladin® Air Z O<sub>2</sub> considers your individual gas mixture, depth and time profile, as well as workload and water temperature. Relying on the latest results of medical and physiological research for its decompression modelling, the Aladin® Air Z O<sub>2</sub> differs from other diving computers in a number of significant ways:

-  Diving with SCR and Oxy2 enables the calculation of oxygen toxicity and decompression to be on the basis of the actual composition of the inhaled gas.
-  The Aladin® Air Z O<sub>2</sub> indicates on the lower display the actual oxygen percentage, the ppO<sub>2</sub> and if needed O<sub>2</sub> attention messages and alarms.
-  The workload is calculated from the difference between the automatically registered oxygen fraction of the premixed gas and the actual oxygen percentage of the inspired gas mixture. The sensitivity of the workload detection can be adjusted with DataTalk. Also the diver selected maximum O<sub>2</sub> consumption supported by the SCR has to be programmed in with DataTalk.
- The ZH-L8 ADT decompression calculation model considers eight body tissues as well as the diver's workload and ambient temperature. This allows for a more precise calculation of a modelled risk for decompression sickness which can lead to greater diving safety.
- The gas data – measured by an Oxy2 or a pressure transmitter – are transmitted by wireless to the Aladin® Air Z O<sub>2</sub>. Faulty transmission of data between the transmitter and Aladin® Air Z O<sub>2</sub> is prevented by a number of precautions.
-  If a pressure transmitter is used, the tank pressure can be easily checked at any time. By monitoring the pattern of the changes in gas pressure, the Aladin® Air Z O<sub>2</sub> calculates the diver's workload and provides a prediction of the remaining time allowed at the current depth based upon tank pressure and air consumption. Thus the remaining bottom time (RBT) displayed on the Aladin® Air Z O<sub>2</sub> considers depth, tank pressure, as well as gas consumption to give the diver a more accurate calculation of when the ascent must be begun according to the decompression program.



If a tank with a reserve or "J"-Type valve is used, the reserve must be in the open (down) position in order to receive a correct remaining bottom time (RBT) calculation.

- The Aladin® Air Z O<sub>2</sub> uses both optical and acoustic alarms. The acoustic alarm uses varied sound signals to assist in identifying the reason for the alarm.



You must strictly observe all optical and acoustic alarms and take appropriate action based upon those alarms to avoid serious injury or death from decompression sickness!

- By using the Aladin® Air Z O<sub>2</sub>'s logbook, a diver may directly call up information from the last 19 dives. The last 37 dives and 175 minutes of dive profile in intervals of 20 seconds can be read out into a MemoMouse, which can be later interfaced with a personal computer (windows). The MemoMouse can store up to 58 hours of diving data.
- The Aladin® Air Z O<sub>2</sub> is designed to be mounted on the diver's left or right wrist, which offers the maximum freedom of movement as well as easy operation and use.

## 4 The Calculation Model ZH-L8 ADT

### 4.1 Description

The Aladin® Air Z O<sub>2</sub> uses the decompression calculation model known as the ZH-L8 ADT. This model uses eight compartments or "tissue" groups with nominal half time periods from 5 to 640 minutes. This model differs considerably from other models by its consideration of the following additional physiological processes:

1. Blood perfusion to the body's organs is not constant. Skin and muscle tissues are in particular subject to changes in blood perfusion, depending on temperature and workload. Changes in blood perfusion to these organs change their nitrogen saturation tolerance. The model used by the Aladin® Air Z O<sub>2</sub> takes these effects into account and thus the "skin" and "muscle" compartments in the Aladin® Air Z O<sub>2</sub> show variable half-time periods and saturation tolerances. Decompression information is calculated according to the diver's individual workload and decrease in skin temperature. The decrease in skin temperature is based upon the water temperature and the dive time. By considering these changes in saturation, the time that must be spent at the surface prior to flying may be considerably increased, depending upon the depth, time, and temperature of a dive, as well as the diver's workload during that dive.
2. The decompression model used by the Aladin® Air Z O<sub>2</sub> considers nitrogen in both its dissolved as well as its gaseous phase (microbubbles). Formation of microbubbles is considered to be a strong indicator of a high risk of decompression sickness. The Aladin® Air Z O<sub>2</sub> model calculates the formation of micro-

## 4 The Calculation Model ZH-L8 ADT

bubbles depending on various assumed influences in arterial and venous blood. In normal, slow ascents, microbubbles form mainly in venous blood. During fast ascents, microbubbles may also form in arterial blood and in the body's tissues as well. If a particular dive profile may result in the creation of microbubbles according to the Aladin® Air Z O<sub>2</sub>'s model, decreased bottom time and/or increased decompression times as well as increased "no fly" time will be indicated.

- Microbubbles can form if the diver makes too fast an ascent, ignores required decompression stops, or makes repeated ascents during a dive (yo-yo diving). These microbubbles can form in arterial blood as well as in the body's tissues. If these microbubbles partially impair circulation, the rate of gas diffusion and saturation tolerance for those tissues immediately surrounding this area of impaired circulation are changed. If required, both decompression time and RBT will be adjusted in such a way that already existing microbubbles will stop growing. Increased decompression time will also assist those local areas of impaired circulation to desaturate with less risk of decompression sickness.
- The calculation of microbubbles results in altered ascent instructions. If microbubbles are assumed to be present based on the data used by the Aladin® Air Z O<sub>2</sub>, the ascent rate to the surface is reduced to 7 metres/minute. This will help prevent the formation of microbubbles in the arterial circulation and minimizes formation of microbubbles in the venous circulation after the dive.

### 4.2 Advantages

On the first dives following responsible diving procedures, a diver using the Aladin® Air Z O<sub>2</sub> should never require decompression stops, although a one to three minute safety stop between 3 and 5 metres is recommended for every dive. If, however, unplanned circumstances arise during the dive which increase the risk of decompression sickness, the Aladin® Air Z O<sub>2</sub> can, if closely followed, reduce the risk by reducing remaining bottom time and/or increasing decompression time. Some of the more common risk situations are as follows:

- Repetitive dives, especially those deeper than 20 metres and those with short surface intervals.
- Repetitive diving over the course of several successive days.
- Diving in cold water.
- Diving with increased workloads.
- Yo-yo diving (repeated descents and ascents to the surface during a given dive).

## 4 The Calculation Model ZH-L8 ADT / 5 Safety in Diving

- Flying within 24 hours after diving.
- Excessive ascent rate.

If a diver experiences any of these risk factors while diving, the Aladin® Air Z O<sub>2</sub> will decrease remaining bottom time without requiring decompression, or will add required decompression time in order to help minimize the risk of decompression sickness.

If signs or symptoms of decompression sickness occur after diving with Aladin® Air Z O<sub>2</sub>, seek IMMEDIATE treatment at the nearest recompression facility.

### 5 Safety in Diving

Together with an Oxy2 or pressure transmitter the Aladin is an extremely versatile tool which can increase your diving comfort and safety. As with any diving tool, however, ultimate responsibility for diving safety remains with the individual diver. The same responsible diving practices taught by all diving certification agencies are still absolutely necessary in order to safely dive with the Aladin® Air Z O<sub>2</sub>.

Certain mistakes which may be made by a diver, such as ascending at an excessive rate, going too deep, or staying too long at depth, may be overcome if the diver carefully follows the Aladin® Air Z O<sub>2</sub>'s corrected ascent instructions. Of course, the Aladin® Air Z O<sub>2</sub> can do nothing to prevent the occurrence of lung overexpansion injuries or nitrogen narcosis, whose avoidance lies solely with the individual diver.

The Aladin® Air Z O<sub>2</sub> is a highly sophisticated technical instrument which, if used and maintained properly, will have high reliability. Despite this no dive should be made with an Aladin® Air Z O<sub>2</sub> without a thorough understanding of decompression theory and dive table use, and every diver must have a set of decompression tables with him on every dive.



Do not use the Aladin® Air Z O<sub>2</sub> without a set of accepted nitrox diving tables with you as a back up decompression tool on every dive.

Should decompression sickness occur, whether the Aladin® Air Z O<sub>2</sub> was used correctly or not, a detailed history of the previous dives may be used to allow a better diagnosis and the most effective treatment for the diver.

## II Aladin® Air Z O<sub>2</sub> – The System

1	Description	1.1	Structure _____	18
		1.2	Reliability of transmission _____	19
2	Pressure transmitter and Oxy2	2.1	Pressure transmitter operating modes and functions _____	20
		2.2	Oyx2 operating modes and functions _____	21
		2.3	Data transmission and reception _____	22
3	Dive Computer	3.1	Operation _____	23
			Active backlight _____	24
		3.2	Operating modes _____	29
4	Setting Up (Oxy2, press. transmitter, Air Z O <sub>2</sub> )	4.1	Fitting the Oxy2 to a rebreather _____	34
		4.2	Fitting of pressure transmitter _____	35
		4.3	Remarks about pairing _____	37
		4.4	How to check that the computer is paired correctly _____	38
		4.5	Pairing of Oxy2 and dive computer _____	38
		4.6	Pairing of press. transmitter and dive comp. _____	40

# 1 Description

## 1.1 Structure

The Aladin® Air Z O<sub>2</sub> system consists of four units:

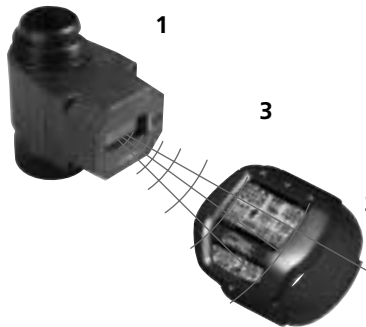

1  The Oxy2 is fitted "in line" to the inhalation hose of the semi closed rebreather (SCR) and measures the actual oxygen fraction of the inspired gas mixture. This information is transmitted to a paired wireless Aladin® Air Z O<sub>2</sub>. This is the basis for the calculation of both oxygen toxicity and decompression, based on the real values of the inhalation gas.

2  With open circuit breathing systems a **pressure transmitter** is used, which is installed at the high pressure outlet of the first stage regulator. It measures tank pressure and transmits the results to the dive computer, where they are further analysed for the calculation of gas mixture consumption and dive data.

3 The **dive computer** displays only important data. The upper display shows general dive data and decompression data. The lower display shows data from either an Oxy2 or pressure transmitter.

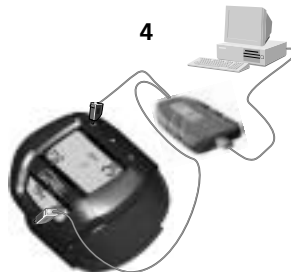
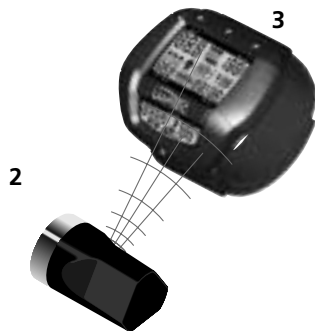

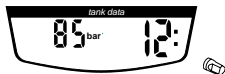
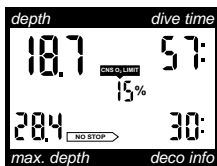

4 The dive computer has a data memory which stores the dive data. The data can be downloaded out into a **MemoMouse** from where they can be transmitted to a Windows® **personal computer** with the logbook program DataTrak. MemoMouse and DataTrak are available as an option.

It is possible to use Aladin® Air Z O<sub>2</sub> as a conventional dive computer without pressure transmitter or Oxy2. In this case calculations depending on gas mixture data are not available and the lower part of the display will not show gas mixture data.

## 1.2 Reliability of transmission

Data transmission from pressure transmitter or Oxy2 to receiver is supported by various levels of redundancy in order to warrant undisturbed and reliable reception:

1. Each Oxy2 or pressure transmitter works with an allocated address. This address is communicated to the dive computer on pairing. There are more than 60,000 addresses. The pairing of transmitter and receiver is also carried out by a process with various safety levels in order to prevent faulty pairing.
2. Data are transmitted with an average interval of 5 seconds. The exact point in time of the transmission is variable. This prevents two transmitters from disturbing each other for longer periods.

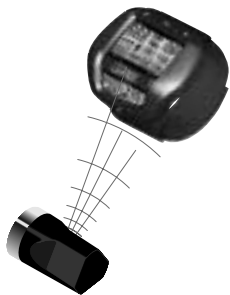

## 1 Description

3. Together with the data additional information is transmitted. This additional information allows the Aladin® Air Z O<sub>2</sub> to reconstruct faulty data and recognize useless data.



By means of these redundant measures, faulty transmission is almost impossible. These transmitted measurements are subjected to an additional plausibility check. Only such data are used which are sensible in the current situation.

## 2 Pressure transmitter and Oxy2

### 2.1 Pressure transmitter operating modes and functions

Off-mode:

When the tank valve is turned off and the regulator purged the pressure transmitter is in the off-mode. In that case, gas mixture pressure is measured every 5 seconds. When pressure increases (on opening the valve), the pressure transmitter leaves the off-mode automatically. When the tank-valve is closed and the regulator purged (pressure sinks below 8 bar), the transmitter falls back into off-mode.

Pair-mode:

After switching on (opening the tank valve), the pressure transmitter sends its address to the dive computer for a short time. During this time the dive computer can be paired to the pressure transmitter.

Transmission-mode:

As long as tank-pressure is decreasing (during normal breathing) the pressure is transmitted to the dive computer on average every 5 seconds.

## 2 Pressure transmitter and Oxy2

**Standby-mode:** If there is no decrease in tank-pressure (no breathing), the transmission is stopped after 3 minutes in order to save energy. Pressure measuring continues. As soon as breathing is resumed the pressure transmitter returns to transmission-mode.



The Aladin® Air Z O<sub>2</sub> pressure transmitter will start working when the tank valve is first opened or when gas mixture is drawn through the regulator. The pressure transmitter will not work if either the tank valve is turned off and the regulator purged or if no gas mixture has been drawn through the regulator for a period of three minutes.

### 2.2 Oxy2 operating modes and functions

**Switching on:** The Oxy2 can be switched on and off manually or automatically by dipping into water.

**Checking:** Before each dive the Oxy2 has to be checked and a calibration may be required (see Oxy2 Manual).

**Calibration:** The turnable switch has to be turned from position „RUN“ to „CAL“ and after completing the calibration back to „RUN“ (see Oxy2 Manual).

**Pair-mode:** A pairing is necessary every time you change from pressure transmitter to Oxy2. The Oxy2 sends a pairing data string at the beginning of the battery and O<sub>2</sub> sensor lifetime check, just after the Oxy2 has been switched on. For detail on Oxy2 pairing see page 38.

**Transmission:** For as long as it is switched on and the switch is in „RUN“ position, the Oxy2 transmits at approximately every 5 seconds the measured oxygen fraction.

**Switching off:** The Oxy2 automatically switches off if a dive as not commenced within 30 minutes of either switching on the Oxy2 or a recalibration was done. After a dive it switches automatically off after 15 minutes.

## 2 Pressure transmitter and Oxy2

### 2.3 Data transmission and reception



The dive computer can only receive data from the pressure transmitter/Oxy2 if the computer and pressure transmitter/Oxy2 are paired. If the pairing has not been carried out, no gas mixture data will be displayed by the dive computer. In that case, Aladin® Air Z O<sub>2</sub> works as a conventional dive computer.



The Aladin® Air Z O<sub>2</sub> must be paired after each change from using a pressure transmitter (air/nitrox) to an Oxy2 or the opposite!

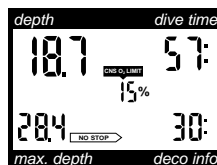
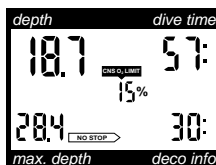
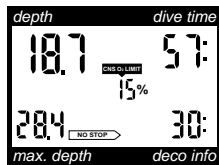

without pressure transmitter/Oxy2

## 3 Dive Computer

### 3.1 Operation

**Switching on display:** – automatically, on submerging in water or when adaptation to atmospheric pressure is necessary.

– manually by manipulating contacts on housing.

**Switching off display:** – automatically, after three minutes without operation.

Aladin® Air Z O<sub>2</sub> has 4 operating contacts B, E, +, – on the outside of the housing. For manual operation, touch base contact B and any one of the other three contacts above the display with moistened fingers.



**Contact B:** Base contact, which has to be touched for all operations.

**Contact E:** Enter contact (together with B). It serves to switch on the computer, to activate the logbook and the O<sub>2</sub>% mix function. It is also used to confirm inputs and is therefore comparable to the ENTER- or RETURN-key of a computer.

**+ / – contacts:** They initiate together with contact B the selection and operation of the logbook and O<sub>2</sub>% mix functions.

### 3 Dive Computer

#### Active backlight

The display of the Aladin® Air Z O<sub>2</sub> can be illuminated both on the surface and underwater.

The backlight can be switched on by pressing the unit above the display.

The light will turn off automatically after 7 seconds.

The backlight can only be activated if the computer display is on.



- The active backlight is no substitute for a dive torch. When diving at night or at increased depth we recommend the use of a dive torch.
- Replace the battery if the battery warning appears.





On page 2 of the English manual you will find a reference guide.

On page 3 of the German manual you will find an openable operating scheme.

1

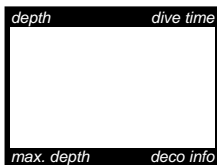

2

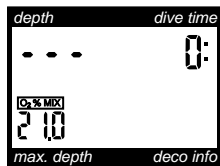

Ready-mode

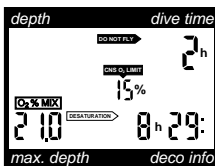

Surface-mode

3

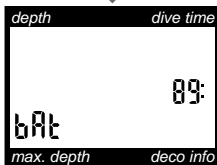

1. The Aladin® Air Z O<sub>2</sub> is in a state of rest; no information is displayed (—>sleep-mode or —>surface-sleep-mode).

2. Bridging B and E activates the display —>ready-mode or —>surface-mode.

3. A second bridging of contacts B and E activates the display of the remaining battery capacity of the Aladin® Air Z O<sub>2</sub> for approximately 5 seconds. As soon as the battery capacity is 0%, a battery alarm is sent (see page 51). There is still a small reserve left at bAt 0%.

### 3 Dive Computer

4



Ready-mode



Surface-mode

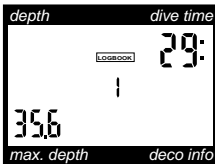

#### 4a Selecting the logbook function:

B and +

Cancel: B and -

or automatically after three minutes

#### 4b Activating the logbook:

B and E. Aladin® Air Z O<sub>2</sub> shows the most recent dive.

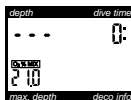
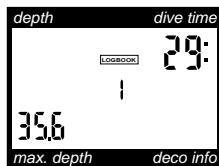

Ready-mode

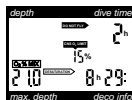

Surface-mode

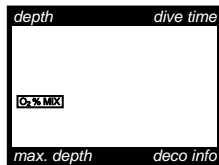
or after  
3 minutes**4c Leaving the logbook:**

B and E

or automatically after three minutes.

**5a Selecting the O<sub>2</sub>% Mix function:**

B und -.

Cancel: B and +:

or automatically after three minutes.

5

### 3 Dive Computer

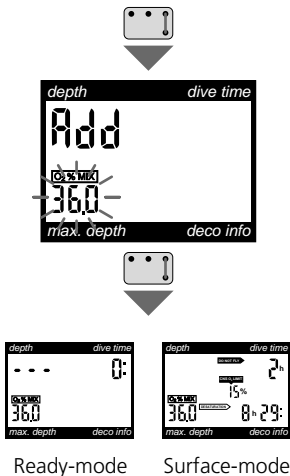

#### 5b Activating the O<sub>2</sub>% Mix function:

B and E

By B and + or B and – the percentage of oxygen is set.

#### 5c Leaving the O<sub>2</sub>% Mix function:

B and E

or automatically after three minutes  
(new setting is not accepted).



 When used with Oxy2 the value for the O<sub>2</sub>% Mix will be automatically determined and replaces the previous value.

## 3.2 Operating modes

Aladin® Air Z O<sub>2</sub> works in various operating modes:

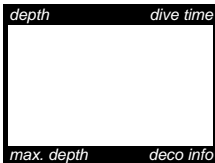
**Sleep-mode:**

Activation: automatically

When Aladin® Air Z O<sub>2</sub> is not used, it is in the sleep-mode.

The display does not show any information. The computer is briefly activated once every minute to measure atmospheric pressure. The display remains switched off. If a change in altitude is recognized, Aladin® Air Z O<sub>2</sub> switches to —>surface-mode for 3 minutes and afterwards back to the surface-sleep-mode. The increasing of the pressure from descending, automatically activates the dive-mode.

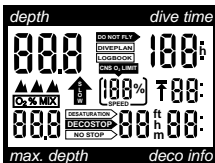
**Ready-mode:**

Activation: By touching contacts B and E from sleep-mode.

To check the display, all signs light up for 5 seconds

After activation the Aladin® Air Z O<sub>2</sub> switches into ready-mode. Once in ready-mode, the display is switched on and the set percentage of oxygen is shown. In certain circumstances altitude sections are also displayed. If the pressure transmitter or Oxy2 is switched on and located within transmitting distance, either the tank-pressure or the oxygen fraction is displayed, otherwise <--> will be displayed.



By touching contacts B and E in the ready-mode once more, Aladin® Air Z O<sub>2</sub> will display its remaining battery life in percent. Three minutes after activating the ready-mode, Aladin® Air Z O<sub>2</sub> will fall back into the —>sleep-mode.

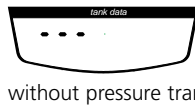
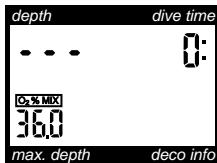

without pressure transmitter/Oxy2

### 3 Dive Computer

#### Dive-mode:

Activation: automatically at depth of about 0.5 m.

In dive-mode, all diving functions are monitored, i.e. depth and dive time are displayed, maximum depth is stored, saturation of tissues is calculated depending on workload and temperature, no-stop time or decompression prognosis is determined, ascent rate is controlled and displayed and the correctness of the decompression procedure is supervised.

The set percentage of oxygen or the oxygen fraction of the premixed gas – determined by the Oxy2 – is displayed at the beginning of a dive until maximum depth is reached, but at least for the first 5 minutes of the dive.

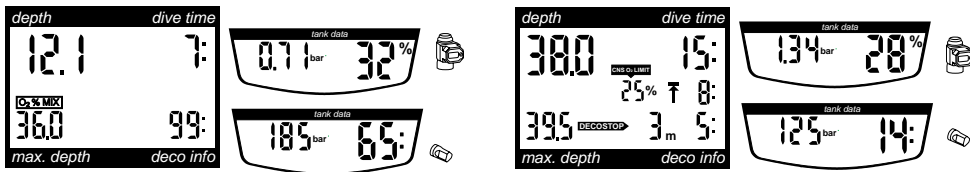

#### Wait-mode:

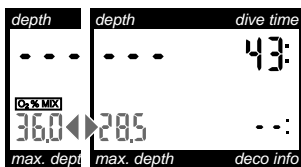

Activation: automatically on reaching the surface

The wait-mode is activated if the diver surfaces (diving depth less than 0.5 m). At the surface, the dive is not completed and entered into the logbook for an interval of 5 minutes.

This allows the short surfacing for orientation or tank exchange.

During the 5 minutes waiting time, the set percentage of oxygen is displayed alternatively with the maximum depth.

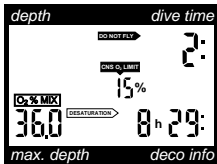

### Surface-mode:

Activation: automatically after a dive or when changing altitude.

After a dive has been completed, Aladin® Air Z O<sub>2</sub> is in surface-mode. All data belonging to the surface interval are calculated and displayed: simulation of microbubble formation, actualization of oxygen toxicity and nitrogen saturation of the tissues depending on the calculated skin temperature and the assumed work load at the surface, calculation of desaturation time, and no fly interval. Desaturation time is determined either by oxygen- or nitrogen saturation, depending on the gas requiring the longer time. Oxygen saturation <CNS O<sub>2</sub> %> is displayed and adjusted until the value becomes 0%.

In order to save energy, Aladin® Air Z O<sub>2</sub> goes into “surface-sleep”-mode after 3 minutes. The functions of surface-mode are then carried out in the background. The atmospheric pressure is measured in surface-sleep once every minute. If the atmospheric pressure decreases, for example in case of change of altitude, Aladin® Air Z O<sub>2</sub> switches from sleep-mode or from surface-sleep into surface-mode automatically and displays the adaptation time. The adaptation time is the time after which all body tissues have adapted to the ambient pressure (= desaturation time).

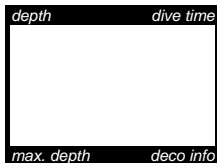

### Logbook-mode:

Activation: manually by contacts

Data of 19 past dives can be called up in the logbook-mode. It shows maximum depth, dive time, preceding interval\*, altitude sections, gas mixture consumption (only with pressure transmitter) and, where appropriate, alarms. A dive is entered in the logbook if it has lasted more than 2 minutes. When the dive was a repetitive dive then it also shows the interval which has passed since the last dive or a preceding change of altitude. The last 37 dives and the last 175 minutes of dive-profiles can be downloaded out into a MemoMouse and later from there into a personal computer (Windows®).

\*Preceding interval is only shown when the computer calculated that there was a residual nitrogen uptake at the beginning of the logged dive.

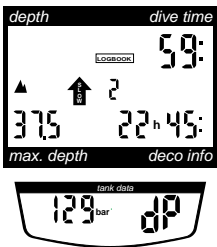

### 3 Dive Computer

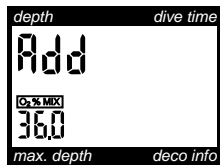

#### **O<sub>2</sub>%-mix-mode** (only if no Oxy2 is used):

Activation: manually by contacts

The O<sub>2</sub>-mix-mode is used to enter the oxygen percentage of the used gas mixture. Values between 21% O<sub>2</sub> and 99% O<sub>2</sub> can be entered. If a pressure transmitter is used, this value is the basis for all calculations. Make sure that the selected value corresponds with the mixture to be used.

The selected O<sub>2</sub>-mix value has to be checked before each dive. A new value probably has to be entered. If an Oxy2 is used together with the Aladin® Air Z O<sub>2</sub> the oxygen fraction of the premix gas is automatically determined.



-  The Oxy2 measures the actual oxygen fraction of the inspired gas mixture. This is the basis for the calculation of both oxygen toxicity and decompression, based on the real values of the inhalation gas. The previous programmed O<sub>2</sub>-mix-value get overwritten with the value measured by the Oxy2.

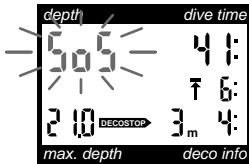

- The time to reset the <O<sub>2</sub>% MIX> – entered manually or automatically by the Oxy2 – to air (21% O<sub>2</sub>) can be set with DataTalk between 1 hour to „no reset“ (default).

**SOS-mode:**

Activation: automatically

If the diver remains above a depth of 0,5 metres for more than three minutes without observing the prescribed decompression, the computer switches into SOS-mode after the dive and displays <SOS> instead of the depth. The computer is locked from use for the next 24 hours. Desaturation is still calculated including microbubbles in the tissues. Diving is again possible after 24 hours, but the SOS-mode can influence the calculations of Aladin® Air Z O<sub>2</sub> for three days after the incident due to the possible presence of microbubbles.



- If a diver using Aladin® Air Z O<sub>2</sub> experiences a diving accident resulting in decompression sickness, the dive can be analyzed by means of the MemoMouse and DataTrak-software.
- An automatic program transmits the logbook data – after connecting the dive computer via MemoMouse with a PC – once a minute from the locked dive computer to the personal computer. Dive computer, MemoMouse and PC need to be connected. The PC has to be ready for receiving data and the DataTrak „download-procedure“ has to be activated.



Serious injury or death may result if a diver does not seek immediate treatment at a recompression chamber should any signs or symptoms of decompression sickness occur after a dive.

## 4 Setting Up (Oxy2, Pressure transmitter and Dive Computer)

### 4.1 Fitting the Oxy2 to a rebreather

The Oxy2 is fitted "in line" to the inhalation hose of the semi closed rebreather (SCR). To get an optimal transmission, the Oxy2 has to be aligned as shown:



Position for left side inhalation hose and lefthanders.



Position for right side inhalation hose and lefthanders.



Position for left side inhalation hose and righthanders.



Position for right side inhalation hose and righthanders.



The Oxy2 may only be mounted into the inhalation hose of the semi-closed rebreather! Otherwise the calculation of decompression and the oxygen toxicity are based on wrong data and this could result in death or serious injury.

It is recommended to mount the dive computer on the same side that the Oxy2 is located.

### 4.2 Fitting of pressure transmitter

The transmitter is fitted at the high pressure (HP) outlet of the regulator's first stage before the first dive.

#### Procedure:

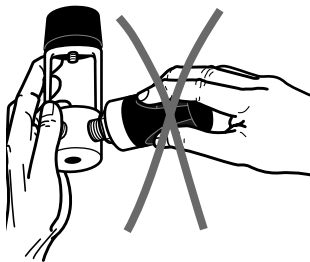

Do not hold the pressure transmitter by its plastic part.

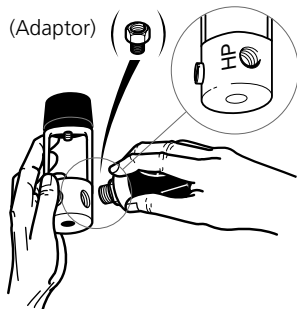

Fit the transmitter to the HP-outlet. If the threads do not match, get an adaptor from your diving retailer.

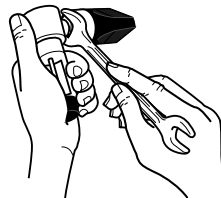

Tighten the transmitter by means of a size 19 wrench.

## 4 Setting Up (Oxy2, Pressure transmitter and Dive Computer)

It is advisable to mount the transmitter on the same side that the computer is located. This is the optimal position for transmission.

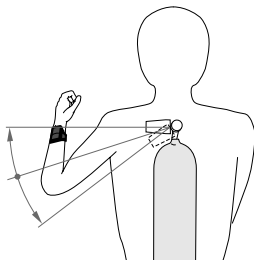

Position of the pressure transmitter for left-handers.

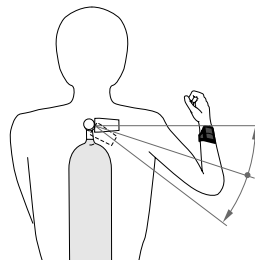

Position of the pressure transmitter for right-handers.

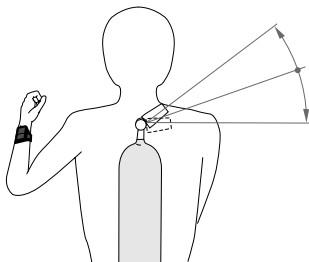

Position of the pressure transmitter for left-handers, if there is no connection possible on the left hand side.

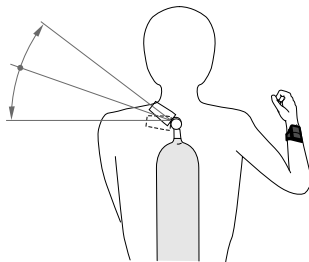

Position of the pressure transmitter for right-handers, if there is no connection possible on the right hand side.

### 4.3 Remarks about pairing

In order to be sure that Aladin® Air Z O<sub>2</sub> receives and uses the data of its own pressure transmitter, or Oxy2, the units must be paired to each other.

Pairing is necessary:

- before the first use of Aladin® Air Z O<sub>2</sub> with the pressure transmitter or Oxy2.
- if you use a new pressure transmitter, Oxy2 or a new computer.
- after changing from a pressure transmitter to an Oxy2 or the reverse.
- after changing from a nitrox pressure transmitter to an air pressure transmitter or the reverse.
- after changing the battery of the dive computer or pressure transmitter.



Oxy2 and Aladin® Air Z O<sub>2</sub> must be paired everytime you change from using a pressure transmitter to an Oxy2 or the reverse!



- The pairing of a transmitter or Oxy2 with a dive computer remains valid until a new pairing is carried out – the pairing can therefore be carried out at home. It must in any event be done once before the system is first used. A new pairing procedure is always necessary when a new transmitter, a new Oxy2 or a new dive computer is used and after changing the battery of the dive computer or pressure transmitter.
- Before every dive check that the lower part of the display shows either the tank pressure (pressure transmitter) or the oxygen fraction (Oxy2).

## 4 Setting Up (Oxy2, Pressure transmitter and Dive Computer)

### 4.4 How to check that the computer is paired correctly:

#### Oxy2 and dive computer

1. Switch on the Oxy2 and the dive computer.
2. Compare the lower part of the dive computer with the Oxy2 display. Pairing has been carried out correctly if the oxygen data is displayed within approximately 10 to 15 seconds. This delay is because of the start-up transmission procedure and a data plausibility check.





pairing with Oxy2

#### Pressure transmitter and dive computer

1. Switch on the computer manually (B and E) and bring it into the transmitting range of the transmitter.
2. Open the tank valve while the regulator is closed. The transmitter switches on automatically.
3. Check the display in the lower part of Aladin® Air Z O<sub>2</sub>: Pairing has been carried out correctly if the pressure is displayed within approximately 10 to 15 seconds.



pairing with pressure transmitter

-   If there is no pairing of Oxy2 and computer or pressure transmitter and computer, <---> is displayed instead of oxygen data or the pressure. In that case, Oxy2 or pressure transmitter and computer have to be paired.



no pairing

### 4.5 Pairing of Oxy2 and dive computer:

1. Switch on the Oxy2. Make sure that the turnable switch is in position „RUN“.
2. Switch on the dive computer manually (B and E) and move it into the position shown below.



## 4 Setting Up (Oxy2, Pressure transmitter and Dive Computer)



Oxy2 and dive computer must be in physical contact during all the pairing procedure.

3. Bridge the Oxy2 contacts E and B (switching on, sensor capacity check).
4. The dive computer shows after a short time a flashing <PAIr> in the lower display.
5. In order to confirm the pairing, the B- and E-contacts have to be bridged within 5 sec. A bleep confirms the input and the <PAIr>-display still remains. The computer and Oxy2 must remain in physical contact until the confirmation has been done.
6. Oxygen data is displayed after approximately 10 seconds.
7. In case of faulty pairing, the display <FAIL> appears instead of <PAIr>. In that case, the pairing procedure has to be repeated.



10 sec



## 4 Setting Up (Oxy2, Pressure transmitter and Dive Computer)

### 4.6 Pairing of pressure transmitter and dive computer



1. Shut the valve, purge the regulator and wait for 15 seconds.
2. Switch on the dive computer (contacts B and E) and move it into the position shown below.



Pressure transmitter and dive computer must be in physical contact during all the pairing procedure.

3. Open the tank valve. The transmitter briefly sends a pairing sequence to the computer.



4. The dive computer shows a flashing <PAIR> in the display-position of tank pressure shortly after the valve has been opened.



5. In order to confirm the pairing, the B- and E-contacts have to be bridged within 5 sec. A beep confirms the input and the <PAIR>-display remains still. The computer and pressure transmitter must remain in physical contact until the confirmation has been done.

10 sec 





6. Tank pressure is displayed after approximately 10 seconds.



7. In case of faulty pairing, the display <FAIL> appears instead of <PAIR>. In that case, completely purge the regulator and repeat the pairing procedure. This is only possible after at least 15 seconds.

### III Diving with Aladin® Air Z O<sub>2</sub>

1	Terminology/Symbols	4.1	Deco data during no-stop phase _____	42
		1.2	Display during decompression phase _____	43
		1.3	Indications on the lower display _____	43
		1.4	Nitrox information _____	44
2	Attention Messages and Alarms	2.1	Attention Messages _____	46
		2.2	Alarms _____	49
		2.3	Alarm low battery _____	51
3	Preparation for a Dive	3.1	Preparation for a Dive with Oxy2 _____	51
		3.2	Preparation for a Dive with press. transm. _____	53
		3.3	Setting the gas mixture _____	54
4	Functions during the Dive	4.1	Dive time _____	55
		4.2	Current depth _____	56
		4.3	Maximum depth _____	56
		4.4	Ascent rate _____	57
		4.5	Partial pressure of oxygen (ppO <sub>2</sub> ) _____	59
		4.6	Oxygen toxicity (CNS O <sub>2</sub> % ) _____	59
		4.7	Oxygen fraction of the inspired gas mixture _____	61
		4.8	Decompression information _____	61
		4.9	Tank pressure  _____	63
		4.10	Increased workload warning _____	64
		4.11	Interruption of transmission _____	65
		4.12	Remaining Bottom Time RBT  _____	65
5	Functions at the Surface	5.1	End of a dive _____	67
		5.2	Desaturation time _____	68
		5.3	No fly time _____	68
		5.4	Warning of bubbles _____	69
6	Diving in Mountain Lakes		_____	70

# 1 Terminology/Symbols

The information on the display of the Aladin® Air Z O<sub>2</sub> varies depending on the kind of dive and the dive phase.

## 1.1 Deco data during no-stop phase

**No-stop phase:** Dive phase during which ascent is allowed without decompression stops.

**Dive time:** Time of the dive below depth of 1.2 m.

**CNS O<sub>2</sub> Limit:** Oxygen toxicity.

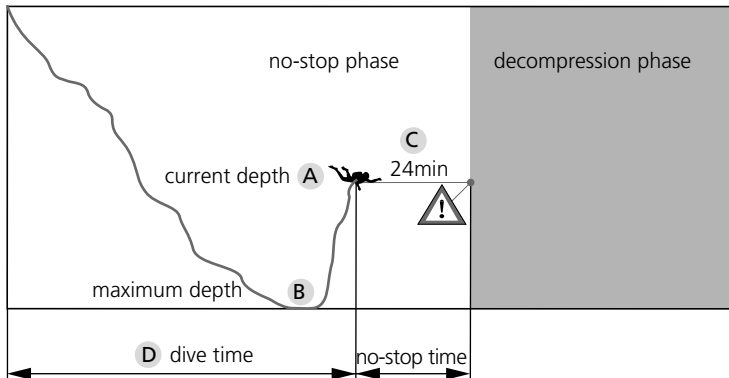
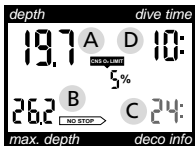

## 1.2 Display during decompression phase

**Decompression depth:** Lowest stage is displayed.

**Decompression time:** Prescribed duration of the decompression stop at the displayed decompression stage.

**Total ascent time to surface:** Total ascent time including decompression stops.

**CNS O<sub>2</sub> LIMIT:** Oxygen toxicity.

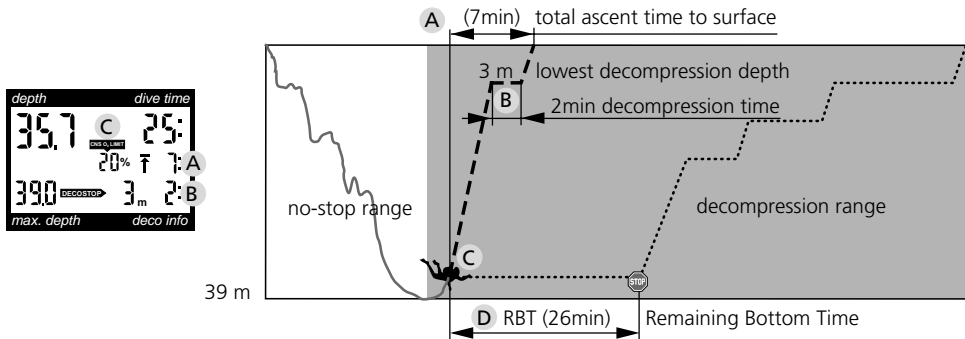

## 1.3 Indications on the lower display



**Partial pressure of oxygen:** <pO<sub>2</sub>> only indicated if an Oxy2 is used. (see page 59)

**Oxygen fraction:** <O<sub>2</sub>%> only indicated if an Oxy2 is used. (see page 61)



When used with an Oxy2 the Air Z O<sub>2</sub> gives no warnings regarding the reserve of gas! Check frequently the pressure gauge.



**Tank pressure:**

**RBT:**

- 📄 Only available if a pressure transmitter is used.
- 📄 (Remaining Bottom Time) time, for which the gas mixture supply is sufficient at the current depth, until ascent must be started (only with pressure transmitter). Illustration on page 43 and explanation on page 65.

### 1.4 Nitrox information (O<sub>2</sub> information)

For dives with compressed air in normal recreational diving nitrogen is the decisive gas for the decompression calculations. When diving with nitrox, the toxicity of oxygen rises with the increase of the portion of oxygen and increasing depth and can limit dive time and the maximum depth. Aladin® Air Z O<sub>2</sub> includes this in the calculations and displays the necessary information:

<O<sub>2</sub>%>:

📄 The Oxy2 is fitted “in line” to the inhalation hose of the semi closed rebreather (SCR) and measures the actual oxygen fraction of the inspired gas mixture. This is the basis for the calculation of both oxygen toxicity and decompression. The Aladin® Air Z O<sub>2</sub> warns the diver acoustically and optically if the oxygen fraction is lower than 19%.

<O<sub>2</sub>%MIX>

📄 Percentage of oxygen: For open circuit systems (pressure transmitter) the percentage of oxygen in the Nitrox mixture has to be entered manually. It can be set between 21% (normal compressed air) and 99% O<sub>2</sub>.



<pO<sub>2</sub>>

📄 Partial pressure of oxygen: When used with an Oxy2 the Aladin® Air Z O<sub>2</sub> shows the actual value.

## 1 Terminology/Symbols



ppO<sub>2</sub> max

  Maximum allowable partial pressure of oxygen: The higher the percentage of oxygen in the used mixture, the smaller the dive depth at which the tolerable partial pressure of oxygen (ppO<sub>2</sub> max) is reached. Default setting is a limit of 1.5 bar, it can be changed with the DataTalk-program in the range of 1.2 to 1.95 bar. The Aladin® Air Z O<sub>2</sub> does not display the entered ppO<sub>2</sub> limit, but warns the diver acoustically and optically if he reaches the depth at which the ppO<sub>2</sub> limit is reached.



The CNS O<sub>2</sub>%-value/alarm is not influenced by the selected ppO<sub>2</sub>max.-setting.

<CNS O<sub>2</sub> LIMIT>

Oxygen toxicity: With the increased percentage of oxygen, the oxygen in the tissues, especially in the central nervous system (CNS) becomes important. If the partial pressure of oxygen rises above 0.5 bar, the CNS O<sub>2</sub> value increases, if the partial pressure of oxygen is below 0.5 bar, the CNS O<sub>2</sub> value decreases. The closer the CNS O<sub>2</sub> value comes to 100%, the nearer comes the limit, where symptoms can occur. See page 47 and 50.

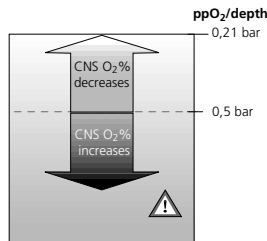

Nitrox diving and diving with a semi-closed rebreather may only be attempted by experienced divers with special training.

## 2 Attention Messages and Alarms

Aladin® Air Z O<sub>2</sub> draws the diver's attention to certain situations and warns the diver of unsafe diving practices. Attention messages and alarms are always optical and acoustic underwater, at the surface they are only optical except for the decompression alarm and low oxygen fraction (<19% O<sub>2</sub>, Oxy2 only).



The acoustic attention messages (but not the alarms) can be switched off (see page 88).

### 2.1 Attention messages

Attention messages are communicated to the diver visually by symbols, letters or flashing figures. In addition, two short acoustic sequences can be heard (in an interval of 4 seconds) in two different frequencies. Attention messages come up in the following situations:

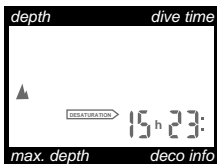

#### Dive in mountain lake

On a change of altitude, the altitude section (0-3) and adaptation time is shown. See page 70.

»)) 4 sec «))

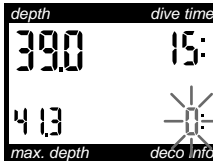

#### End of no-stop phase

In order to prevent a decompression dive: ascend a few metres.

#### Partial pressure of oxygen reaches limit

»)) 4 sec «))

The partial pressure of oxygen reaches the set value (to be set not higher than 1.6 bar by MemoMouse and DataTalk-software). See pages 79 and 59.

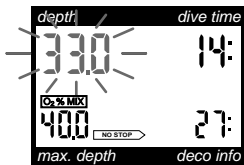

### Oxygen toxicity

») 4 sec »)

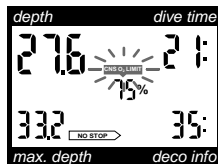

Oxygen toxicity of 75% is reached. Avoid a further increase of the value by beginning the ascent.

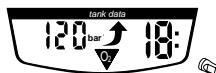

**Remaining bottom time less than 3 minutes**

») 4 sec »)

Start ascent.

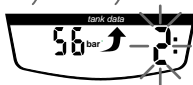

**No reception of gas-data**

») 4 sec »)

») 4 sec »)

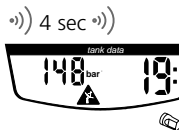

(interruption of transmission) If this message becomes frequent, check the position of the Oxy2 or pressure transmitter. See also "Setting up" on page 34 or 36).

**Increased workload warning**

») 4 sec »)

») 4 sec »)

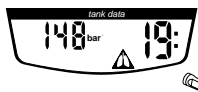
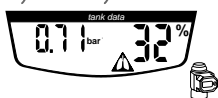

Breathe more slowly, relax.  
See page 78 and 64.

## 2 Attention Messages and Alarms

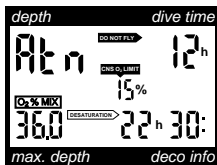

### Warning of bubbles

Extension of the surface interval is recommended. See pages 69 and 78.

») 4 sec »)



### One O<sub>2</sub>-sensor measures wrong

The Oxy2 continues to work. You can continue your actual dive cautiously. Check frequently the oxygen fraction value! Calibrate the Oxy2 after you have finished your dive. See also Oxy2 manual.

») 4 sec »)



### Both O<sub>2</sub>-sensors measure wrong

When a reliable measurement is not possible. The Air Z O<sub>2</sub> switches for its calculations to the premix value, which the Oxy2 measured automatically at the start of the dive. The displayed oxygen fraction and the oxygen partial pressure are now related to the premix. The dive computer then has to be used as though there is no Oxy2. It is recommended that an ascent is made. Calibrate the Oxy2 after the dive. See also Oxy2 manual.

### 2.2 Alarms

Alarms are given to the diver optically by flashing symbols, letters or figures and symbols. In addition, an acoustic sequence in one frequency can be heard during the whole duration of the alarm.

An alarm occurs in the following situations:

»))      »))      »))

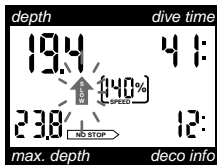

#### Excessive ascent rate.

Reduce ascent rate. See page 76.

»))»))»))      »))»))»))



#### Remaining bottom time zero

(gas mixture supply too low)

Reserve gas mixture supply may be insufficient to reach the surface safely. Start ascent at once!

With an Oxy2 the Air Z O<sub>2</sub> gives no warnings regarding the reserve of gas! Check frequently the pressure gauge.



### 2.3 Alarm low battery

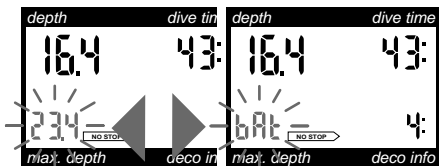



#### Dive computer battery low:

In dive-mode, <bat> is indicated by a flashing display and alternating with the display of maximum depth as soon as battery capacity is 0%. In ready-mode and surface-mode, <bat> is shown instead of maximum depth. Take the unit to your authorised Uwatec Dealer!

#### Oxy2 or pressure transmitter battery low:

<bat> flashing and alternating with the display of <pO<sub>2</sub>> (Oxy2) or with the tank pressure (pressure transmitter).

 The battery of the Oxy2 can be replaced by a authorised retailer or – if the user knows how to solder properly – by the user.

 The battery of the Aladin® Air Z O<sub>2</sub> has to be replaced by your authorised Uwatec Dealer.

## 3 Preparation for the Dive

### 3.1 Preparation of a dive with Oxy2

The following description of the preparation of a dive is based on the assumption that the Oxy2 is fitted correctly „in line“ to the inhalation hose of a semi closed rebreather and that it is paired with the Aladin® Air Z O<sub>2</sub>. See pages 34, 38.

### 3 Preparation for the Dive

1. Switch on the Oxy2 and check it according to the Oxy2 manual.

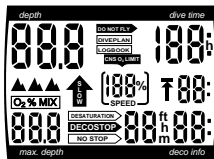

2. Switch on the Aladin® Air Z O<sub>2</sub> manually by bridging the contacts B and E with moistened fingers. Check test display: are all displays lit? 



3. Check transmission from Oxy2 to dive computer. Compare the display of the Oxy2 with the Aladin® Air Z O<sub>2</sub> values after approx. 10 seconds. The O<sub>2</sub>%-values of the Aladin® Air Z O<sub>2</sub> are rounded to 1%.



Oxy2 LCD

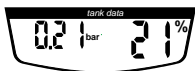

4. Flush the SCR and compare the O<sub>2</sub>% of the lower display with the O<sub>2</sub>% of your premix. See also page 53.

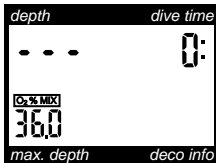

5. The Aladin Aladin® Air Z O<sub>2</sub> is now in the ready-mode.

It switches on automatically on being submerged in water and activates dive-mode, when a depth of more than 0.5 metre is reached. The depth indication may be delayed for a few seconds.



To correctly calculate the workload the Aladin Aladin® Air Z O<sub>2</sub> needs to know the maximum of the expected O<sub>2</sub> consumption rate supported by the SCR in its current setup. The default value is 2.5 litres/min. To change the value use DataTalk (see page 106).

### 3 Preparation for the Dive



– In extremely pure freshwater, it is possible that the Aladin® Air Z O<sub>2</sub> will not automatically activate the dive-mode.

#### 3.2 Preparation for a Dive with pressure transmitter

The following description of the preparation of a dive is based on the assumption that the pressure transmitter is mounted correctly at the HP-outlet of the regulator (see pages 36, 37) and that it is paired with Aladin® Air Z O<sub>2</sub> (see page 38).





If the Aladin® Air Z O<sub>2</sub> pressure transmitter is not correctly mounted or is not correctly paired, it will not perform properly and serious injury or death may result.

1. Mount regulator with pressure transmitter on tank.
2. Check the reserve valve of your tank, the reserve valve must be open.

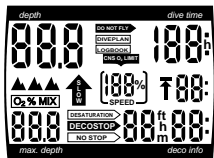

If a reserve or “J”-type valve is used, the valve must be in the open (down) position for the Aladin® Air Z O<sub>2</sub> to work correctly.



3. Switching on Aladin® Air Z O<sub>2</sub> manually:  
Bridge contacts B and E  with moistened fingers. Check test display: are all displays lit?
4. Open valve (pressure transmitter switches on automatically).



### 3 Preparation for the Dive



5. Check transmission from transmitter to dive computer.  
Check tank pressure (after approx. 10 seconds). If not enough pressure is indicated, change tank.

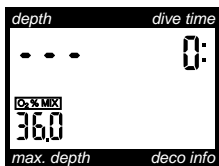

6. The Aladin® Air Z O<sub>2</sub> is now in ready-mode.  
It switches on automatically on being submerged in water and activates dive-mode, when a depth of more than 0.5 metre is reached. The depth indication may be delayed for a few seconds.



In extremely pure freshwater, it is possible that the Aladin® Air Z O<sub>2</sub> will not automatically activate the dive-mode.



#### 3.3 Setting the gas mixture



Before every dive – unless an Oxy2 is used\* – , you must check if the setting of the gas mixture (percentage of oxygen) on your Aladin® Air Z O<sub>2</sub> corresponds to the mixture in your tank. Reset the mixture if necessary:

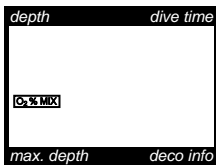

1. Switch on computer manually and check the set percentage of oxygen (O<sub>2</sub>% MIX).
2. Switch to O<sub>2</sub>% MIX input stage by bridging B and –.



3. Confirm by bridging B and E, the O<sub>2</sub>-value starts flashing.

\* The Oxy2 automatically determines the O<sub>2</sub>% mix for the Aladin® Air Z O<sub>2</sub>.

### 3 Preparation for the Dive / 4 Functions during the Dive

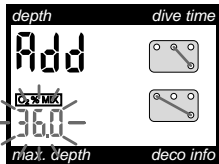

4. Bridging B and + will increase the percentage of oxygen (from 21% to 99%), bridging B and – decreases the percentage of oxygen.



5. Confirm with B and E. Aladin® Air Z O<sub>2</sub> switches back into ready-mode.



Before every dive, make sure that the setting of the gas mixture corresponds to the actual mixture used. A wrong setting causes the Aladin® Air Z O<sub>2</sub> to miscalculate. If the percentage of oxygen is set too low this can lead to oxygen intoxication without warning. If the value is set too high decompression damages due to nitrogen saturation may occur without a warning from the Aladin® Air Z O<sub>2</sub>.

## 4 Functions during the Dive

### 4.1 Dive time

The whole time spent below a depth of 1.2 metres is displayed as dive time in minutes. While the dive time is running, the colon on the right of the figures is flashing in one second intervals. Maximum dive time displayed is 199 minutes.

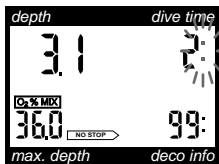

If a dive lasts longer than 199 minutes the dive time display starts again at 0 minutes.

## 4 Functions during the Dive

### 4.2 Current depth

Current depth is given in 10 cm-increments. On switching on and at a diving depth of less than 0.5 metres the void display <---> appears.

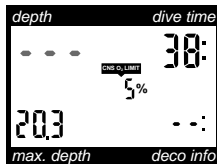
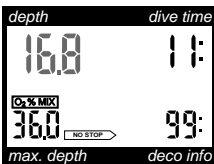

Depth measurement is based on fresh-water. Therefore, Aladin® Air Z O<sub>2</sub> shows a slightly greater depth than actually true when diving in salt water, depending on the salinity of the water.

### 4.3 Maximum depth

The maximum depth is displayed if it is lower than the current depth. To prevent the display changing very frequently when diving in the vicinity of the maximum depth, it is only displayed if it exceeds the current depth by more than 1 metre.

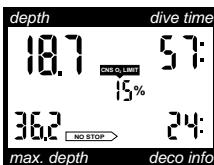

The set percentage of oxygen (pressure transmitter) or the automatically determined premix O<sub>2</sub>%-value (Oxy2) is displayed instead of the maximum depth until a first maximum depth is reached (but at least for the first 5 minutes of the dive).

## 4.4 Ascent rate

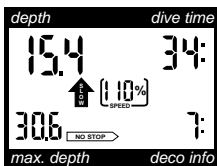

Optimal ascent rate varies depending on depth between 7 and 20 m/min. It is displayed in percent of the reference variable. If the ascent rate is greater than 100% of the set value, the black arrow <SLOW> appears. If the ascent rate exceeds 140%, the arrow starts flashing.

The Aladin® Air Z O<sub>2</sub> provides an acoustic alarm if the ascent rate is 110% or greater of the set value. The intensity of the alarm increases in direct proportion to the degree that the prescribed ascent rate is exceeded (see page 76).













- The prescribed ascent rate must be observed at all times! Exceeding the prescribed ascent rate can lead to microbubbles in the arterial circulation which can lead to serious injury or death due to decompression sickness.



- The Aladin® Air Z O<sub>2</sub> may require a decompression stop even within the no-stop phase because of the danger of formation of microbubbles due to an improper ascent.
- The decompression time necessary for the prevention of microbubbles can increase massively if the ascent rate is exceeded.
- From great depth, too slow an ascent may cause heightened saturation of tissues and an extension of both decompression time and total ascent time. At shallow depth, a slow ascent may shorten the decompression time because the tissues are desaturating during the slow ascent.
- The display of the ascent rate has priority over the CNS O<sub>2</sub>%-value display.

## 4 Functions during the Dive

### Messages:

	Ascent rate	Optical alarm	Acoustic alarm			
			)	)	)	)
			)	)	)	)
			)	)	)	)
			)	)	)	)

Excessive ascent rates for longer periods are entered in the logbook.

Response:

Reduce ascent rate

## 4 Functions during the Dive



### 4.5 Partial pressure of oxygen (ppO<sub>2</sub>)

«) 4 sec «)

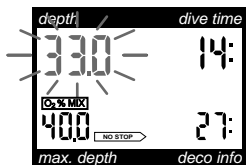

The tolerable partial pressure of oxygen can be set by means of a MemoMouse and the DataTalk software to between 1.2 and 1.95 bar (see page 88). The set value is not displayed.

The actual ppO<sub>2</sub> is displayed only if an Oxy 2 is used.



**Messages:** Depending on the setting for the ppO<sub>2</sub> limit and the mixture used the ppO<sub>2</sub> limit will be reached at different depths. When this is reached the Aladin® Air Z O<sub>2</sub> sends an acoustic attention message and the current depth display starts flashing the ascend arrow and the O<sub>2</sub>-warning-triangle appears.

**Response:** Ascend to a shallower depth in order to diminish the danger of oxygen toxicity.



The allowed maximum depth should not be exceeded or only for a short period. Disregarding the warning can lead to danger from oxygen toxicity.

### 4.6 Oxygen toxicity (CNS O<sub>2</sub>%)

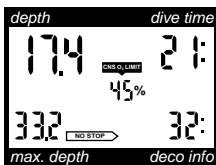

Oxygen toxicity is calculated on line as a function of depth and workload values and the gas mixture. The toxicity is displayed in 5% increments as a percentage of the maximum value tolerated (O<sub>2</sub> clock), together with the symbol <CNS O<sub>2</sub> LIMIT>. This display is in the same place as the ascent rate display. The Aladin® Air Z O<sub>2</sub> takes into consideration that the physical performance of a diver influences oxygen toxicity.

## 4 Functions during the Dive

«)» 4 sec «)»

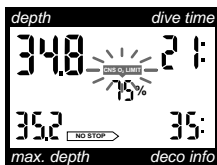

Messages: An acoustic signal is sent if oxygen toxicity reaches 75%. The symbol <CNS O<sub>2</sub> LIMIT> flashes continuously. The ascent arrow and the O<sub>2</sub>-alarm-triangle is shown.



Response: Go to a shallower depth if necessary.



«)» «)» «)» «)» «)» «)» «)» «)»

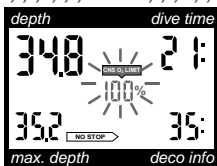

Messages: When oxygen toxicity reaches 100%, an acoustic alarm is sent every 4 seconds. Also CNS O<sub>2</sub>% value, the ascent arrow and the O<sub>2</sub>-alarm-triangle all flash continuously. See also page 79.



Response: Start ascent at once.



- During an ascent and if the CNS O<sub>2</sub>% value does not increase anymore (due to a lower partial pressure of oxygen), the acoustic warning and the ascent arrow are suppressed.
- During the ascent, the display of the oxygen toxicity is replaced by the ascent rate display. If the ascent is stopped, the display changes back to the indication of oxygen toxicity.

### 4.7 Oxygen fraction of the inspired gas mixture

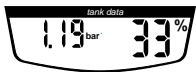

The Oxy2 measures in the inhalation hose of a SCR the actual oxygen fraction of the gas mixture. The measured value is transmitted every 5 seconds to the Aladin® Air Z O<sub>2</sub> which displays the rounded (1%) value. See page 80.

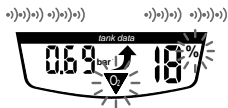

**Message:** If the oxygen fraction is lower than 19% an acoustic alarm is sent every 4 seconds, also the O<sub>2</sub> alarm triangle is flashing.



**Response:** Flush the SCR system and check the tank pressure!  
If necessary change to the backup system.  
Never let the O<sub>2</sub> fraction go below 19%! Danger of hypoxia!

### 4.8 Decompression information

No-stop time is displayed if no decompression stops are necessary. The arrow <NO STOP> is visible if no decompression stops are necessary. The figures indicate no-stop time in minutes.

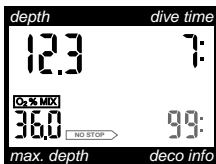

- No-stop display <99:> means remaining time of 99 minutes or more.
- No-stop time is calculated on line and influenced by the actual workload and current water temperature.

## 4 Functions during the Dive

») 4 sec »))

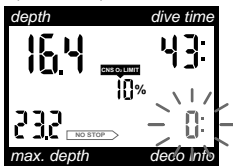

Messages:

There is an acoustic signal if no-stop time is less than 1 minute. In this last minute, the no-stop display shows the flashing value <0>.

Response:

In order to prevent a decompression dive, you must ascend a few metres after this message.



It is dangerous and unsafe diving practice to push a dive computer or any other decompression tool to its limits. Avoid no-stop times of less than three minutes at any given depth.

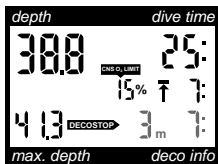

On entering the decompression phase, the arrow <NO STOP> disappears. The arrow <DECO STOP> appears. Right beside the arrow, the deepest decompression stage in metres is displayed. Beside the decompression depth, the decompression time is displayed in minutes for this stage. The display <3m7:> means that a decompression stop of 7 minutes at a depth of 3 metres has to be made. When a decompression stop has been finished, the next higher decompression stop is displayed. When all decompression stops have been made, the arrow <DECO STOP> extinguishes and the arrow <NO STOP> reappears. The indication of time on the lower right shows the no-stop time again.

»))»))»))»))»))»))

»))»))»))»))»))»))

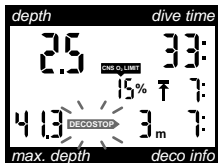

Messages:

The decompression alarm is activated if the decompression stop is ignored. The arrow <DECO STOP> begins flashing and an acoustic alarm is initiated. Due to the formation of micro-bubbles decompression can increase massively if a decompression stop is ignored. When the surface is reached during the decompression alarm, the arrow <DECO STOP> continues flashing, in order to point to the risk of a decompression accident. The SOS-mode is activated 3 minutes after the dive if corrective action is not taken.

If the total (cumulative) duration of the decompression alarm is longer than a minute, it is entered in the logbook.

## 4 Functions during the Dive

Response: Descend to the prescribed decompression depth immediately!

Total time of ascent

As soon as decompression stops are necessary, Aladin® Air Z O<sub>2</sub> shows the total time of ascent. The time of ascent to the first decompression stage and all decompression stops are included.

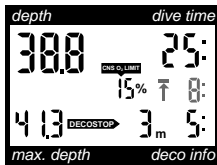

The time of ascent is calculated on the basis of the prescribed ascent rate and a normal workload. Total time of ascent can be subject to change if the ascent rate is not ideal (100%) or with higher workload.



On all dives with the Aladin® Air Z O<sub>2</sub>, make a safety stop for at least one to three minutes within the 3 to 5 metre zone.

### 4.9 Tank pressure (only with pressure transmitter)

Tank pressure is indicated in the lower display.



The tank pressure transmitted to the computer by the transmitter is also used for the calculation of the remaining bottom time (RBT) and the workload\*.

## 4 Functions during the Dive

### 4.10 Increased workload warning

») 4 sec »)

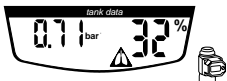

Messages:

In case of increased workload, the Aladin® Air Z O<sub>2</sub> displays a lung symbol in the lower display and an acoustic warning occurs.

Response:

In order to prevent additional saturation, reduce exertion and breathe more slowly. See page 78.

») 4 sec »)



») When used with Oxy2 the Aladin® Air Z O<sub>2</sub> calculates the divers workload using the measured oxygen fraction of the inhalation gas mix and an automatically measured oxygen fraction of the premixed gas.

### 4.11 Interruption of transmission

») 4 sec »)

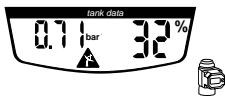

If no data is received for 30 seconds the display of the Aladin® Air Z O<sub>2</sub> shows the interruption of transmission signal (broken antenna) and there is an audible warning. Without a transmission of sensible data in the following 40 seconds <---> appears.

») If the transmission between an Oxy2 and the Air Z O<sub>2</sub> is interrupted, the partial pressure and the oxygen fraction is no longer displayed (alarm signal). The decompression and oxygen toxicity are calculated now on the basis of the automatically determined premix.

») 4 sec »)



») When used with a pressure transmitter the tank pressure and the the RBT (Remaining Bottom Time) is no longer displayed (alarm signal).

») 4 sec »)



») ») If the transmission is interrupted then either the Oxy2 or pressure transmitter or dive computer are not working correctly, or the position of the sender is wrong. As soon as data are transmitted again, the computer restarts to display the data.

#### 4.12 Remaining bottom time RBT (only with pressure transmitter)

RBT is the time left at the current depth until the point of time when the ascent must be started. The RBT is shown in the lower display. The RBT is calculated on the basis of the current tank pressure, the temperature, and the dive data so far registered. The RBT is based on the assumption that the tank pressure should amount to at least 40 bar at the end of the dive. Alterations to this are possible (see page 88).

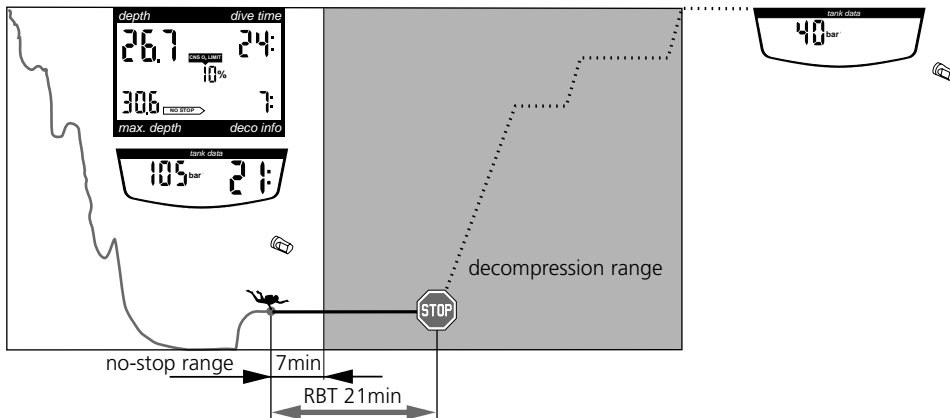

The RBT-value should never reach <0>. With a RBT=0 the remaining tank reserve may not be guaranteed anymore after ascending. It is possible that the gas reserve will not be big enough for the ascent.



Correct calculation of RBT when using a reserve or "J"-type valve is possible only if the reserve function of the valve is in the open (down) position during the dive.

## 4 Functions during the Dive



The acoustic alarm on exceeding the RBT is suppressed at depths less than 7 metres if Aladin® Air Z O<sub>2</sub> is in the no-stop phase.

Messages:



If the RBT drops below three minutes, an acoustic attention signal is activated, the ascent arrow is displayed and the RBT (figures only) starts flashing.



When the last minute has passed (RBT=0) an acoustic attention signal is activated every 4 seconds. The RBT and the ascent arrow start flashing.

Response: Start ascent immediately.

## 5 Functions at the Surface

### 5.1 End of a dive

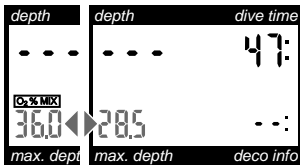

After reaching the surface, Aladin® Air Z O<sub>2</sub> switches into wait-mode automatically for five minutes. This is the time span necessary to recognize the end of the dive. The delay allows for surfacing for a short period for orientation or for a change of tank. During the five minutes waiting time the percentage of oxygen display alternates with maximum depth display. When the dive is closed after 5 minutes in wait-mode, it is entered into the logbook and Aladin® Air Z O<sub>2</sub> switches into surface-mode. In surface-mode, Aladin® Air Z O<sub>2</sub> shows desaturation time, no fly time and CNS O<sub>2</sub>%.



If the tank is changed in this phase, you must make sure that the mixture is exactly the same as the one previously used. If you don't make the next dive with an Oxy2 and you want to dive with another mixture, you must wait at the surface for 5 minutes to allow the Aladin® Air Z O<sub>2</sub> to close the dive. Then the setting of the mixture must be adjusted to the new mixture. Disregarding this rule causes the Aladin® Air Z O<sub>2</sub> to calculate with wrong mixture data. This can lead to injury or death.

## 5 Functions at the Surface

### 5.2 Desaturation time

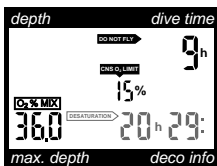

When <DESATURATION> appears, the Aladin® Air Z O<sub>2</sub> is in surface-mode. Desaturation time in hours and minutes, the set mixture (percentage of oxygen) and, if available, oxygen toxicity is displayed next to it. Desaturation time is continually indicated until the next dive or until it reaches zero. The display is switched off to save energy three minutes after the last manipulation is made (surface-sleep-mode).



- In some cases, desaturation times with the Aladin® Air Z O<sub>2</sub> are considerably longer than those of other dive computers. This is because the calculation model assumes reduced physical activity at the surface (therefore less nitrogen off gassing) and uses longer half-times.
- If desaturation time reaches zero, the “tissue” models of the Aladin® Air Z O<sub>2</sub> are desaturated and it switches into the sleep-mode.
- Desaturation time is determined either by oxygen or nitrogen saturation, depending on which gas requires the longer desaturation time. Oxygen saturation (<CNS O<sub>2</sub> LIMIT>) is displayed and adjusted until the value becomes 0%.
- For the calculations of the desaturation and No Fly Time it is assumed that the diver inhales air.

### 5.3 No fly time

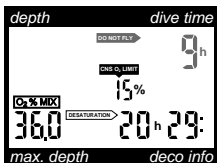

The waiting period until the next flight is indicated as follows: <DO NOT FLY>. Beside this the time in hours that should pass before a flight is displayed.

In some cases the no fly time is considerably longer than with certain other models (because of recalibrated desaturation time).



Flying while the Aladin® Air Z O<sub>2</sub> displays <DO NOT FLY> may lead to serious injury or death from decompression sickness.



For the calculations of the desaturation and No Fly Time it is assumed that the diver inhales air.

#### 5.4 Warning of bubbles

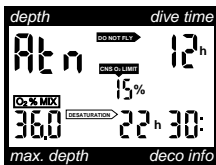

Through repetitive dives microbubbles accumulate in the lungs if the surface interval is not long enough. Ignoring decompression stops or an excessive ascent rate can also lead to bubbles in tissues. In order to reduce the risk of decompression sickness for future repetitive dives, the surface interval should be planned long enough to reduce the risk of decompression sickness. If Aladin® Air Z O<sub>2</sub> calculates that the formation of microbubbles occur during the surface interval, it will advise a diver to extend the surface interval. If the display <Atn> (=attention) is visible instead of the depth during the surface interval (surface-mode), the diver should not undertake another dive. Through the extension of the interval the diver may prevent a high concentration of bubbles in the lungs during the planned dive and avoid a higher risk situation. See also page 78.



- If the dive has to be made during <Atn>-time, the <Atn> time of the following dive can increase considerably.
- If the dive is made in spite of the display <Atn>, the diver must cope with a significantly shorter no-stop time and an extension of decompression time.

## 6 Diving in Mountain Lakes

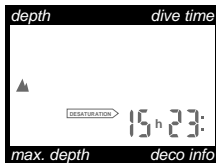

Aladin® Air Z O<sub>2</sub> measures the atmospheric pressure even while in sleep-mode. If the computer detects a higher altitude, it switches into surface-mode automatically. Desaturation time indicated at this moment refers to adaptation time at this altitude. If diving starts within this adaptation time, Aladin® Air Z O<sub>2</sub> treats it as a repetitive dive, since the body still has a higher saturation.

The entire altitude range is divided into four sections which are influenced by barometric pressure. That is why the defined altitude sections overlap on their fringes. The altitude section is indicated at the surface, in the logbook and in the dive planner by stylised mountains, if a mountain lake altitude is reached. Sea level to an altitude of approximately 1000 metres is not indicated. In the following, you can see the approximate altitude ranges of the four sections:

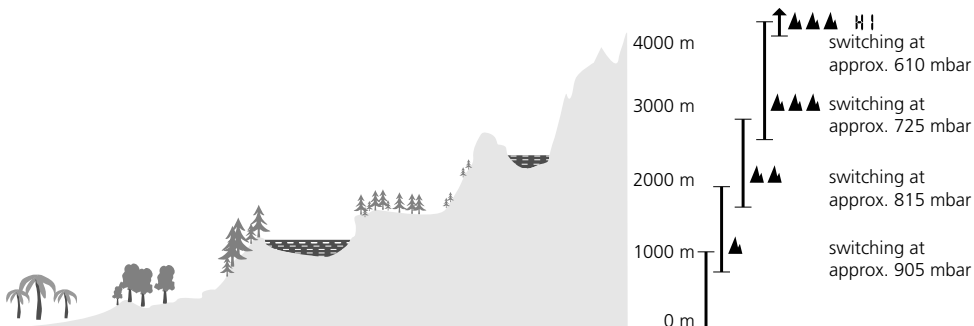

In order to assure optimal decompression even at higher altitudes, the 3 m decompression stage is divided into a 4 m stage and a 2 m stage (the prescribed decompression depths are, in sequence, 2 m, 4 m, 6 m, 9 m).

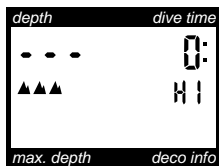

Aladin® Air Z O<sub>2</sub> can be used as a decompression computer in case of an emergency up to an altitude of 4000 m. If atmospheric pressure is below 620 mbar (altitude higher than 4000 m above sea level), no decompression data is displayed. Oxygen toxicity is still calculated. Indication of the RBT is also impossible since decompression data are necessary for its calculation (of course the PPO<sub>2</sub> and O<sub>2</sub>% or tank pressure are still displayed). By the display of the altitude section 3, <HI> (=high) appears, telling the diver that he will not get any decompression information for the dive.



Very small differences in the pressure sensors can cause an indication of different altitude sections of two dive computers at the same altitude on the fringes of the altitude ranges. These differences are not meaningful and do not interfere with the functions of Aladin® Air Z O<sub>2</sub>. But if an altitude section is displayed at sea level or the altitude readouts of two computers differ by more than one altitude section (e. g. section 2 instead of 0), there may be a computer defect. In this case, send your computer back to your retailer for testing.



Diving while at altitude can considerably increase the risk of decompression sickness. Do not undertake high altitude diving without being specifically trained in the special techniques of such diving.



## IV Diving at Reduced Risk with Aladin® Air Z O<sub>2</sub>

IV

### 1 Diving at reduced risk with Aladin® Air Z O<sub>2</sub>

1.1	Diving at reduced risk _____	74
1.2	Diving at reduced risk for the first dive _____	74
1.3	Minimizing risk on repetitive dives _____	75
1.4	Response in increased risk situations _____	76

## 1 Diving at Reduced Risk with Aladin® Air Z O<sub>2</sub>

### 1.1 Diving at reduced risk

Aladin® Air Z O<sub>2</sub> recognizes and reacts “intelligently” to certain risk situations, although of course it is much better that each individual diver avoid these higher risk situations altogether. If a decompression accident does occur, the optional MemoMouse and DataTrak software allows the analysis of the dive profile and certain risk parameters to provide for more complete information for treatment purposes.

Analysis of the most recent results of decompression research and statistical analysis of diving accidents involving decompression sickness supports the following guidelines for diving with a reduced risk of decompression sickness.

The following suggestions are highly recommended:



Neither the Aladin® Air Z O<sub>2</sub> nor any other diving computer or decompression table can guarantee that decompression sickness will not occur even if the computer or table is used correctly and all of the following precautions are followed.

### 1.2 Diving at reduced risk for the first dive

The following are highly recommended suggestions to prevent risky situation during the first dive:

- Always make your first dive the deepest dive of the day.
- Always make the deepest descent of each given dive on a particular day at the beginning of that dive.
- Avoid repeated ascents and descents (yo-yo diving).
- Plan the dives shorter if they are made in cold water.
- Avoid repeated heavy workload whilst at depth.
- Ensure that you have enough Gas for the Ascent. Do not use the RBT to the limit if prolonged ascents or an increased rate of breathing (currents...) are expected.
- If the ascent is made in a current, do not use up the RBT to the end.
- Plan the dives shorter if they are made in cold water.
- After finishing the decompression or at the end of a no-stop dive, the final stage of the ascent should be as slow as possible.
- On all dives with the Aladin® Air Z O<sub>2</sub>, make a safety stop for at least one to three minutes within the 3 to 5 metre zone.
- Check <O<sub>2</sub>% MIX> (gas mixture) and the dive depth limit given by the maximum ppO<sub>2</sub> selected.

## 1 Diving at Reduced Risk with Aladin® Air Z O<sub>2</sub>

- If the ascent arrow appears, start ascending.
- If the flashing ascent arrow appears, start to ascend at once.
- Observe <CNS O<sub>2</sub> LIMIT> (ascend at 75%).
- Comply with the ascent rate and decompression stops if any.
- If the Aladin® Air Z O<sub>2</sub> fails at any time during the dive, the dive must be terminated, and appropriate surfacing procedures should be initiated immediately.
- You MUST follow the ascent rates as indicated by the Aladin® Air Z O<sub>2</sub> and if the computer should fail for any reason, you must ascend at a rate of no greater than 10 metres per minute.
- All divers using dive computers to plan dives and indicate or determine decompression status must use their own computer which they take with them on all dives.
-  If your diving cylinder is equipped with a reserve or "J"-type valve, make certain that the reserve is in an open (down) position. Failure to keep the reserve open will result in the improper calculation of dive data depending on tank pressure.
- On any given dive, both divers in a buddy pair must follow the most conservative dive computer for that particular dive.
- You MUST be familiar with all signs and symptoms of decompression sickness before using the Aladin® Air Z O<sub>2</sub>! Seek IMMEDIATE treatment for decompression sickness should any of these signs or symptoms occur after a dive! There is a direct correlation between the effectiveness of treatment and the delay between the onset of symptoms and the treatment for decompression sickness.
- Always observe the visual and acoustic alarm signals of the Aladin® Air Z O<sub>2</sub>. Avoid situations of increased risk which are marked with a warning sign in this operating manual.

### 1.3 Minimizing risk on repetitive dives

With consecutive repetitive dives, there will be excess nitrogen in the body due to the accumulation of nitrogen on the preceding dives. Depending on the length of the surface interval, there could even be gaseous nitrogen (microbubbles) in your body. This accumulation of both absorbed as well as gaseous nitrogen in the body can greatly increase the risk of decompression sickness on subsequent dives. That risk can be minimized.

- Respect the rules for the first dives.
- Wait until <CNS O<sub>2</sub> LIMIT> is less than 40%.
- Match gas mixture to the intended dive.

## 1 Diving at Reduced Risk with Aladin® Air Z O<sub>2</sub>

- Descend less deep for the repetitive dive than for the previous dive.
- Plan for a minimum surface interval of three to four hours.
- Do not attempt to repetitive dive if the <Atn> is visible on the display.
- Take a day off from diving every week.
- Repetitive dives after exchanging the dive computer: Wait at least 24 hour before you start with the repetitive dive.

### 1.4 Response in increased risk situations

If the dive includes an increased risk situation, Aladin® Air Z O<sub>2</sub> reacts automatically to warn the diver of this risk and increase required decompression, as the case may be. A change of decompression may be indicated to minimize the risk. The diver can further reduce the risk by following conservative diving practices on the next dive and at the same time avoiding long decompression stops.

A few examples are on the following pages:

#### Situation 1:

#### The diver ascends too rapidly:

Reaction of computer:

The model calculates the formation of bubbles due to the excessively rapid ascent. The no-stop time is shortened or a longer (and eventually at greater depth) decompression prescription is displayed in order to assure increased decompression. See pages 49, 57 and 58.

#### Recommended response of the diver

During the dive:

Observe the new decompression prescription shown by Aladin® Air Z O<sub>2</sub>.

After the dive:

Watch for symptoms of arterial gas embolism and decompression sickness. Seek immediate medical attention at a recompression chamber should any signs or symptoms of decompression sickness appear. Before the next dive, plan a sufficiently long interval (display <Atn> should have disappeared).



An excessive ascent rate can lead to serious injury or death from decompression sickness. Failure to seek IMMEDIATE treatment for any signs or symptoms of decompression sickness after a dive may result in serious injury or death.

**Situation 2:**                    **The diver disregards the prescribed decompression depth.**

Reaction of computer:        The model calculates the formation of bubbles due to ignoring decompression. A longer (and eventually at greater depth) decompression is displayed in order to assure sufficient time for desaturation. See page 50 and 62.

### **Recommended response of the diver**

During the dive:                Descend to the prescribed decompression depth at once.  
Do not descend to greater depths during the dive.  
Observe the decompression prescribed by Aladin® Air Z O<sub>2</sub>.

After the dive:                 Watch out for symptoms of arterial gas embolism and decompression sickness.  
  
Before the next dive, plan a sufficiently long interval (display <Atn> should have disappeared).



Failure to comply with all decompression information on the Aladin® Air Z O<sub>2</sub> may result in serious injury or death due to decompression sickness. There is a risk of decompression sickness on every dive even if all precautions described in this manual are taken.

## 1 Diving at Reduced Risk with Aladin® Air Z O<sub>2</sub>

**Situation 3:**                    **The diver is physically exerting himself or herself, (e.g. swimming against the current).**

Reaction of computer:    A shorter RBT or an extension of decompression time. See page 47 and 64.

### **Recommended response of the diver**

During the dive:

- Avoid further physical exertion if possible. Relax.
- Frequently check the RBT (pressure transmitter only) or oxygen fraction (Oxy2 only) and decompression information on your Aladin® Air Z O<sub>2</sub>.
- RBT may decrease considerably. Decompression time may increase considerably.

After the dive:

Refrain from heightened physical exertion on your next dive.  
Increase your surface interval.

---

**Situation 4:**                    **It is very unlikely to have a surface interval long enough to clear the <Atn> prior to the next dive during an organized dive trip from a boat. This previous buildup of nitrogen must be taken into consideration for the next dive.**

Reaction of computer:    Aladin® Air Z O<sub>2</sub> calculates a shorter no-stop time or longer decompression prescription to reduce the risk of decompression sickness. See page 69.

### **Recommended response of the diver**

During the dive:

Dive conservatively on all repetitive dives. Limit your maximum depth to no more than 25 metres at the very beginning of the dive, do not allow the RBT to go below three minutes, and make a very slow ascent.

After the dive:

Before the next dive, plan a sufficiently long surface interval (<Atn> display should disappear).

---

**Situation 5:** <CNS O<sub>2</sub>%-value> reaches 100%.

Reaction of computer: An acoustic and visual alarm is given. The CNS O<sub>2</sub>%-value, the ascent arrow and the O<sub>2</sub>-warning triangle are flashing. See also page 50, 59 and 60.

**Recommended response of the diver**

Ascend immediately until ppO<sub>2</sub> is less than 0.5 bar and the buzzer stops.

---

**Situation 6:** ppO<sub>2</sub> reaches the set value.

Reaction of computer: An acoustic warning is given, depth indication is flashing (attention message), the ascent arrow and the O<sub>2</sub>-warning-triangle appears. See page 46 and 59.

**Recommended response of the diver**

Ascend above critical depth limit.  
Observe <CNS O<sub>2</sub>%-value> carefully.

**Situation 7: O<sub>2</sub> fraction too low (less than 19%)**

Reaction of computer:  Every 4 seconds an acoustic alarm is given, the O<sub>2</sub>-warning triangle is flashing. See page 50 and 61.

**Recommended response of the diver:**

During the dive: Flush the SCR and check the tank pressure! If necessary switch to the backup system.

After the dive: Check the dosage of the SCR.

## V Logbook

V

1	Survey	82
2	Selection and Activation	83
3	Selection of Dive	84
4	Leaving the Logbook-Mode	85
5	Output on PC	86

## 1 Survey

The Aladin® Air Z O<sub>2</sub> records the last 37 dives and the dive profiles of the last 175 minutes of diving (see „Output on PC“ page 86). The last 19 dives can be displayed directly on the dive computer. A dive is only entered in the logbook if the dive time is longer than 2 minutes. Displayed information of the dive:

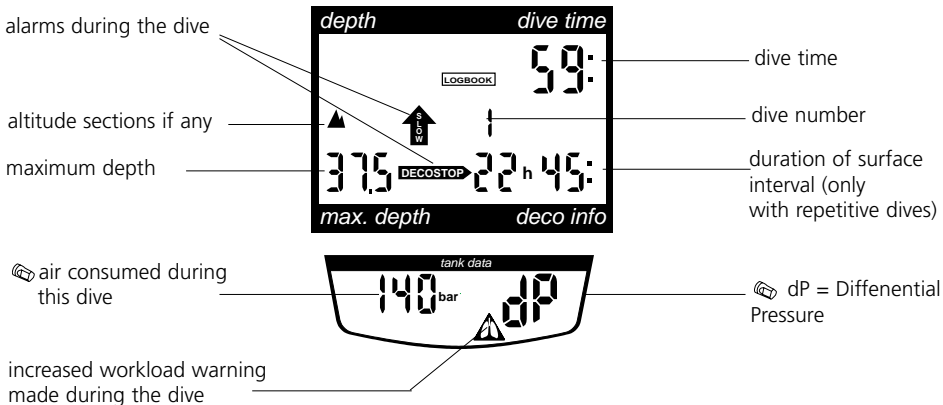

If a dive is started within adaptation time (after a change of altitude), the adaptation time is displayed instead of the surface interval.

## 2 Selection and Activation

V

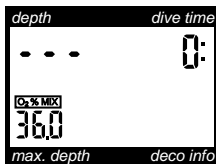

Ready-mode

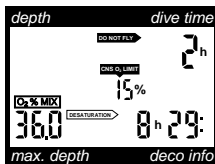

Surface-mode

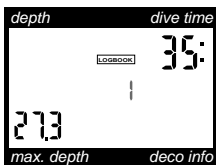
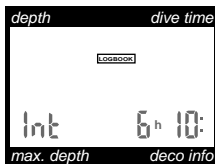
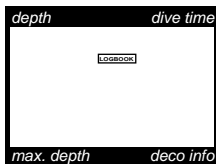

1. The logbook is selected by bridging contacts B and + in ready- or surface-mode. Indication <LOGBOOK> appears. If Aladin® Air Z O<sub>2</sub> has been in surface-mode before, the surface interval appears as well. You go back into ready- or surface-mode by B and -.

2. In order to activate the logbook, bridge contacts B and E. The most recent dive is displayed (DIVE I).

### 3 Selection of Dive

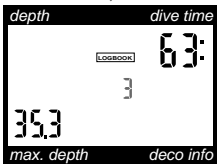
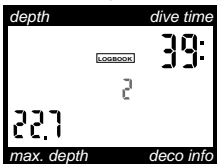
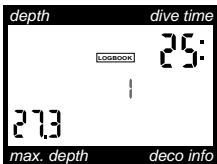

1. Bridge contacts B and + to get the information of the dive preceding the most recent one. Display <DIVE 2> appears.
2. On additional bridging of B and + the logbook jumps to the next older dive (DIVE 3).
3. On constant bridging of the contacts all dives are displayed successively.
4. Bridging contacts B and – allows switching back from older dives to more recent ones.

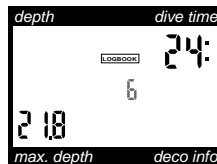

## 4 Leaving the Logbook-Mode

V

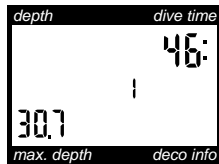

or after 3 minutes

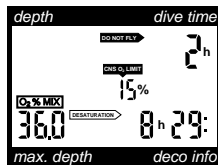
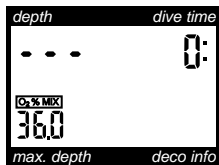

Touch contacts B and E.

Aladin® Air Z O<sub>2</sub> switches back into ready- or surface-mode. This also happens 3 minutes after last activating logbook-mode.

## 5 Output on PC

The Aladin® Air Z O<sub>2</sub> stores data of the last 37 dives including a total of approximately 175 minutes of dive profiles from the last dives. This information can be downloaded into a Memo Mouse (optional), which stores up to approximately 58 dive hours. With the DataTark Windows® software (optional) the information can then be transferred from the MemoMouse to a PC.

Time and date of the dive are entered automatically, based on the clock of the PC-system when the data are transferred via interface.

The possibilities and the procedure of this data transfer are described in a separate manual.







1	MemoMouse, DataTrak and DataTalk	1.1	Personal programming of the dive computer (DataTalk) _____	88
		1.2	Analysis and storage of real dives (DataTrak) _____	89
		1.3	Updates (DataTrak, DataTalk) _____	89

## 1 MemoMouse, DataTrak and DataTalk

The Aladin® Air Z O<sub>2</sub> is able to communicate with a personal computer. The connection is established by contact sensors and the MemoMouse. The MemoMouse and the PC software DataTrak and DataTalk is available as an option. For the Aladin® Air Z O<sub>2</sub> it is only allowed to use DataTalk version 2.0 or higher. Communication with a personal computer (Windows®) has a number of advantages:

### 1.1 Personal programming of the dive computer (DataTalk)

Several parameters can be set individually by the user, e. g.:

- The physical units of water depth and tank pressure can be selected (metric/imperial).
- The attention message acoustic signals can be switched off if desired (see page 46). The actual attention message displays are not affected by the acoustic signal being switched off. The acoustic messages for alarms cannot be switched off. Alarm messages are: RBT below zero minutes (pressure transmitter only), ignoring decompression stop, making too rapid an ascent, exceeding CNS O<sub>2</sub> limit, oxygen fraction below 19% O<sub>2</sub> (Oxy2 only).
-  The calculation of Remaining Bottom Time (RBT) assumes a certain remaining tank pressure at the surface (see page 65). This remaining pressure can be adjusted from 30 to 100 bar.
-  The sensitivity of the warning message “increased workload” can be altered.
- The maximum allowable partial pressure of oxygen can be adjusted between 1.2 and 1.95 bar.
- The time to reset the <O<sub>2</sub>% MIX> – entered manually or automatically by the Oxy2 – to air (21% O<sub>2</sub>) between 1 hour to „no reset“ (default).
-  The the divers maximum physiological O<sub>2</sub>-consumption supported by the SCR can be adjusted.
-  The sensitivity of the workload warning can be adjusted.



ppO<sub>2</sub> max must not be set higher than 1.6 bar



If you switch off the acoustic attention buzzer of the Aladin® Air Z O<sub>2</sub> you must pay careful attention to the visual signals on the face of the Aladin® Air Z O<sub>2</sub>. Failure to follow all alarms whether audible or not may lead to serious injury or death due to decompression sickness, and/or drowning.

### 1.2 Analysis and storage of real dives (DataTrak)

The last approx. 175 minutes of dive time are stored by the dive computer in increments of 20 seconds and can be transferred to the PC. The DataTrak software allows the representation and analysis of the profiles. By this means all relevant data are examined and displayed for every point in time. A lot of additional information such as water temperature, gas mixture consumption etc. can also be viewed. The DataTrak releases 2.0 and higher recognize the Aladin® Air Z O<sub>2</sub> and display the respective data.

The PC program enables the diver to keep a personal logbook. Apart from the last 175 minutes of diving, 37 dives are recorded in the logbook of Aladin® Air Z O<sub>2</sub>. If the data from Aladin® Air Z O<sub>2</sub> are transferred regularly into the MemoMouse and then to the PC, all dives will be stored in the PC with their profiles. Time and date of the dives are automatically recorded and the dives can be printed out on a page for the diver's logbook.



















### 1.3 Updates

The last versions of DataTrak and DataTalk are available for free from the Internet (<http://www.uwatec.com>).





## VII Trouble Shooting

symptom	possible reason(s)	response
No reception of the tank pressure-/oxygen data	 /  and computer are not tuned to each other (paired)	 /  Pair transmitter and computer (see page 38-40).
	 /  or receiver in the computer are defective.	If pairing is not possible with another  /  the receiver in the computer is defective. Have dive computer repaired.
	 Oxy2 switch in position „CAL“.	Turn switch to „RUN“.
	 In surface-mode if there is no decrease in pressure the data will not display (see page 20).	Change the pressure by breathing from the regulator. Data will appear.
	 Automatic switches itself off after interval at surface (see page 21).	Switch on manually.
Bad reception of tank pressure or Oxy2 data.	 /  is not mounted correctly.	Mount  /  correctly (see page 34/35).
	 /  or receiver in the computer is defective.	If pairing is not possible with another  /  the receiver in the computer is defective. Have dive computer repaired.

## VII Trouble Shooting

## symptom

## possible reason(s)

## possible reason(s)

 Displayed tank pressure does not correspond to pressure measured by a manometer (depth gauge).

By compensating for temperature, the pressure displayed is valid at 20 °C. If the gas or water temperature differ from this value, a difference to the value given by a manometer is possible.

Make comparison at 20 °C or check the tank pressure compensated to the atmospheric pressure for comparison (see page 98).

Tank and transmitter do not have the same temperature (only possible in air).

Leave the tank with the regulator mounted and the gas mixture turned on for five to ten minutes.

Manometer/depth gauge is not accurate (temperature 20 °C).

Measure tank pressure with another manometer/depth gauge (at 20 °C).

 The logbook does not show any gas mixture consumption (dp) for a certain dive.

No tank pressure signal was received at the beginning or end of the dive.

Mount transmitter correctly (see page 35).

Transmitter and dive computer were not paired before the dive started.

Pair transmitter and computer (see page 40).

The dive has been made with an Oxy2.

Altitude section does not correspond to the current altitude.

Atmospheric pressure is especially high or low.

Check barometric information.

Ambient air pressure measured by the computer is wrong.

Send in dive computer for servicing (only if altitude section is wrong by more than one section, see page 70).

## VII Trouble Shooting

symptom	possible reason(s)	response
Desaturation time and/or no fly time are very long.	Too many repetitive dives, yo-yo-diving, square profile repetitive dives or disregarding decompression stops. Dissolved nitrogen and/or microbubbles must be off gassed first.	Plan sufficiently long surface interval and dives at lower risk.
<Atn> appears.	Too many repetitive dives, too fast ascents, yo-yo-diving, square profile repetitive dives or disregarding decompression stops. Dissolved nitrogen and/or microbubbles must be off gassed first.	Plan sufficiently long surface interval and dives at lower risk. Review chapters III 5 and IV very carefully.
An unexpected decompression stop appears in place of no-stop time or decompression increases rapidly.	Too rapid an ascent or ignoring decompression stops have caused a large number of microbubbles, which leads to an attention message (warning of bubbles).	Plan sufficiently long surface interval and dives at lower risk. Review chapters III 5 and IV very carefully.
Attention messages are not given acoustically.	The acoustic signal of the attention messages is switched off.	Reactivate attention messages by means of the MemoMouse and DataTalk.
 Remaining bottom time (RBT) always very short.	Remaining pressure is set too high (standard setting 40 bar).	Alter the remaining pressure setting by means of the MemoMouse and DataTalk.
	Reserve valve not open.	Always open reserve valve when using Aladin® Air Z O <sub>2</sub> .

1	Maintenance	_____	96
2	Technical Information	_____	97
3	Conversion of tank pressure	_____	98
4	Warranty		
	3.1	Recognition of warranty _____	99
	3.2	Scope of the warranty _____	99
	3.3	Warranty period and claim _____	99
5	Safety considerations	_____	100
6	Serial No. / Dealer address	_____	102

## 1 Maintenance

Your Aladin® Air Z O<sub>2</sub> is virtually maintenance free. All you need to do is to rinse it carefully with fresh water after each use and to have the batteries changed when needed. To avoid possible problems with your Aladin® Air Z O<sub>2</sub>, the following recommendations will help assure that it will give you years of trouble free service:



- Avoid dropping or jarring your Aladin® Air Z O<sub>2</sub>
- Do not allow your Aladin® Air Z O<sub>2</sub> to be exposed to direct, intense sunlight.
- Rinse your Aladin® Air Z O<sub>2</sub> thoroughly with fresh water after each dive.
- Do not store your Aladin® Air Z O<sub>2</sub> in a sealed container; make sure there is free ventilation.
- If there are problems with operating the contacts, the surface of your Aladin® Air Z O<sub>2</sub> housing can be treated with silicone grease. Use soapy water to clean the Aladin® Air Z O<sub>2</sub> before using silicone grease and dry it thoroughly.
- Do not clean the Aladin® Air Z O<sub>2</sub> with liquids containing solvent.
- There are borings in two of the contacts for the reception of the PC interface connection (MemoMouse). Free these borings from dirt with a needle if necessary.



Take the dive computer or the pressure transmitter to an authorized Uwatec dealer in order to change the batteries. The actual change of the batteries is made at the manufacturer or the importer. The computer is checked for its technical functioning at the same time. Do not attempt to have the batteries changed by anyone other than an authorized dealer. The battery of the Oxy2 can be replaced by a authorised retailer or – if the user knows how to solder properly – by the user.

## 2 Technical Information

VIII

**Operating altitude:** with decompression information: sea level up to approx. 4000 metres  
without decompression information: unlimited

**Operating depth:** No limit for recreational dives.



- Always check the diving limits given by the chosen percentage of oxygen (decompression sickness, oxygen toxicity).
- Do not dive deeper than 40 metres.



**Maximum operating pressure:** 13 bar

**Clock:** quartz timer, display up to 199 minutes

**Operating temperature:** 10° to +50 °C.

**Power supply:** Special battery Uwatec LR07

**Life of the battery:** (standard values) For an average diving time of 60 minutes and a surface interval of 20 hours after every dive

Number of dives per year	Dive computer (years)	 (years)	 (years)
50	7	11	5.5
100	5.5	9.5	4.5
150	4	8	4
300	2.5	6	3

### 3 Conversion of tank pressure

Tank pressure indicated in the lower display may diverge from the information given by a manometer/depth gauge. Aladin® Air Z O<sub>2</sub> always displays pressure converted to a temperature of 20 °C, whereas the mechanical depth gauge displays the actual pressure influenced by temperature.

The figure on the right allows you to compare the information given by a conventional depth gauge and by Aladin® Air Z O<sub>2</sub> at six different temperatures.

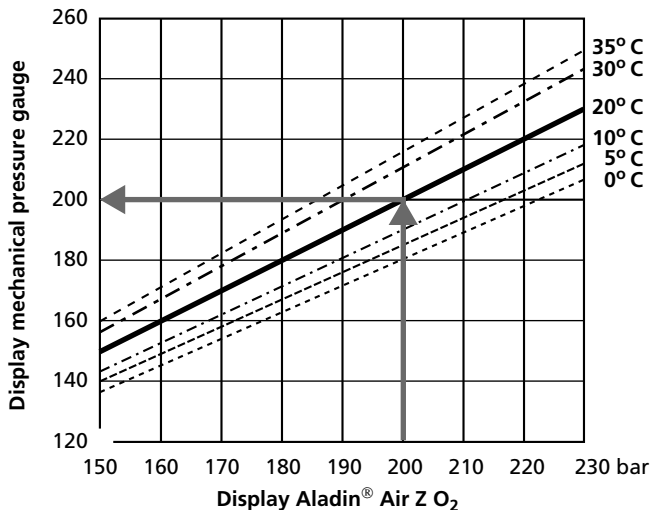

Please pay attention to the following remarks on warranty claims:

### 4.1 Recognition of warranty

The warranty only covers dive computers which have been provably bought from an authorized retailer or from the manufacturer.

### 4.2 Scope of the warranty

The manufacturer will repair all defects which are provably traceable to defects of material or faults in production. The warranty covers the repair of the dive computer free of charge, the replacement of faulty parts or the entire dive computer, respectively.

UWATEC reserves the right to determine the merits of a warranty claim and to determine whether the computer will be repaired or replaced.

Excluded are faults or defects due to:

- excessive wear and tear.
- exterior influences, e.g. transport damage, damage due to bumping and hitting, influences of weather or other natural phenomena.
- servicing, repairs or the opening of the dive computer by anybody not authorized by the manufacturer. This especially concerns the change of batteries for the pressure transmitter as well as for the dive computer.
- pressure tests which do not take place in water.
- diving accidents.



### 4.3 Warranty period and claim

The warranty is given for a period of 12 months. Repairs or replacements during the warranty period do not increase the warranty period.

In order to put forward a warranty claim, send the dive computer together with a dated receipt of the purchase to your authorized retailer or an authorized servicing point.

The manufacturer does not have to accept extensions of the warranty granted by national importers.

## 5 Safety considerations

The Aladin® Air Z O<sub>2</sub> with an Oxy2 or a pressure transmitter gives to the diver a high level of reassurance and safety. However these units can never be a substitute for a thorough diving education. Pay careful attention to warnings given by the Aladin® Air Z O<sub>2</sub>. Do not make risky dives. Pay special attention to the parts of this manual which are marked with  and  !

Follow all standard safe diving practices:

- Never dive without a buddy. The Aladin® Air Z O<sub>2</sub> does not substitute – not even together with an Oxy2– for a dive buddy!
- Only make dives that are appropriate to your level of dive training. Neither the Aladin® Air Z O<sub>2</sub> nor the Aladin® Air Z O<sub>2</sub> together with an Oxy2 increase your knowledge of diving.
- Neither the Oxy2 nor the Aladin® Air Z O<sub>2</sub> warn about nitrogen narcosis!
- Do not dive deeper than the limit given by your SCR.
-  Do not dive deeper than the Oxy2 maximum depth.

This manual is part of the Aladin® Air Z O<sub>2</sub> safety concept. Please confirm that you have read and understood the complete manual:

Place: \_\_\_\_\_ Date: \_\_\_\_\_ Signature: \_\_\_\_\_



**6 Serial No. / Dealer address**



**Serial No. of your  
Aladin® Air Z O<sub>2</sub>:**

**Dealer address:**

(Dealer to affix stamp)

Printed in Switzerland 1/00

Active backlight	24	Gas mixture, setting	53
Alarms	49	Interruption of transmission	47, 64, 92
Ascent rate	16, 49, 57, 76	Logbook	13, 26, 82, 86
Atn	69, 78, 94	Maintenance	96
Attention messages	46	Maximum depth	56
Backlight	24	MemoMouse	19, 86, 88
Battery lifetime	97	Microbubbles	14, 15
Battery alarms	51	Model, calculation model	14, 15
Bubbles, warning of	48, 69, 78	Mountain lakes, diving in	46, 70, 93
CNS see O <sub>2</sub> -Toxicity		Nitrox	10, 44
CNS O <sub>2</sub> Limit	45, 47, 50, 79	No fly time	68, 94
DataTalk	88	No-stop phase	42, 46, 61
DataTrak	86, 89	O <sub>2</sub> fraction	43, 44, 50, 61 80
Deco data during no-stop phase	42, 61	O <sub>2</sub> % mix	27, 32 44
Deco data during decompression phase	43, 62	O <sub>2</sub> partial pressure	43, 44, 46, 59, 79
Decompression stop, ignored	50, 77	O <sub>2</sub> partial pressure, maximum	45
Depth	56	O <sub>2</sub> sensors	48
Depth, current	56	O <sub>2</sub> toxicity	10, 47, 50, 59-60, 79
Desaturation time	68, 94	Oxy2	18, 21
Dive, analysis	98	Oxy2, fitting to a rebreather	34
Dive computer, personal programming	88	Oxy2, preparation of a dive with	51
Dive, end of a dive	67	Oxygen... see „O <sub>2</sub> ...“	
Dive-mode	30	Pairing, check	38
Dive, preparation of a dive with Oxy2	51	Pairing Oxy2 and dive computer	22, 38
Dive, preparation of a dive with pr. transmitter	53	Pairing pressure transmitter and dive computer	40
Dive time	55	Pairing, remarks about	37
Diving in mountain lakes	46, 70, 93	PC, output on PC (Logbook)	86
Operating, dive computer	23	Premix, setting the gas mixture	53
Operating of surface functions, dive computer	23	Preparation of a dive with Oxy2	51
Fly, "no fly time"	68, 94	Preparation of a dive with pressure transmitter	53
		Pressure transmitter	18, 20

Pressure transmitter, fitting	35
Pressure transmitter, preparation of a dive with	53
RBT	13, 43, 47, 49, 65, 94
Ready-mode	29
Remaining bottom time, see RBT	
Risk, diving at reduced risk	74-76
Safety diving	4, 5, 10, 74-46, 100
Sleep-mode	29
SOS-mode	33
Surface interval	78
Surface-mode	31
Surface-mode, operation of functions	23
System	18
Tank pressure	43, 63, 93, 98
Technical information	97
Transmitter, see pressure transmitter	
Transmission system	18-19
Transmission, interruption	47, 64, 92
Transmission, reliability	19
Trouble shooting	92
Updates (DataTrak, DataTalk)	89
Warranty	99
Wait-mode	30
Workload detection with Oxy2	13, 63, 64, 88
Workload detection with pr. transmitter	13, 63, 88
Workload warning	47, 64, 78