



PRESSURE RECEPTACLES WITH BLOCKED OR INOPERABLE VALVES

IGC Document 129/05/E

Revision of EIGA TN 505/86/E

EUROPEAN INDUSTRIAL GASES ASSOCIATION AISBL

AVENUE DES ARTS 3-5 • B-1210 BRUSSELS
Tel: +32 2 217 70 98 • Fax: +32 2 219 85 14
E-mail: info@eiga.org • Internet: <http://www.eiga.org>



PRESSURE RECEPTACLES WITH BLOCKED OR INOPERABLE VALVES

PREPARED BY :

Jean-Paul Barbier	AIR LIQUIDE
Giorgio Bissolotti	SIAD
Simon Christian	AIR PRODUCTS
Kevin Cleaver	BOC
Dieter Heller	LINDE
Joseph Merckaert	AIR LIQUIDE
Bruno Reimann	AIR LIQUIDE
Werner Weterings	SCOTT SPECIALITY GASES
Herman Puype	EIGA

Disclaimer

All technical publications of EIGA or under EIGA's name, including Codes of practice, Safety procedures and any other technical information contained in such publications were obtained from sources believed to be reliable and are based on technical information and experience currently available from members of EIGA and others at the date of their issuance.

While EIGA recommends reference to or use of its publications by its members, such reference to or use of EIGA's publications by its members or third parties are purely voluntary and not binding.

Therefore, EIGA or its members make no guarantee of the results and assume no liability or responsibility in connection with the reference to or use of information or suggestions contained in EIGA's publications.

EIGA has no control whatsoever as regards, performance or non performance, misinterpretation, proper or improper use of any information or suggestions contained in EIGA's publications by any person or entity (including EIGA members) and EIGA expressly disclaims any liability in connection thereto.

EIGA's publications are subject to periodic review and users are cautioned to obtain the latest edition.



Table of Contents

1	Introduction	1
2	Scope and purpose.....	1
3	Definitions	1
4	Why receptacle valves become inoperable	1
4.1	Internal corrosion.....	1
4.2	Mechanical failure.....	1
4.3	Blockages	2
5	Precautions when releasing gas from receptacles with blocked or inoperable valves.....	2
5.1	Personnel safety and training	2
5.2	Equipment.....	3
5.3	Facilities.....	3
6	Introduction to depressurization techniques	3
6.1	Summary of techniques.....	3
6.2	Choice of technique.....	3
7	Release of gas by unconventional operation of the receptacle valve	4
7.1	Partial stripping of the valve to facilitate movement of a broken spindle.....	4
7.2	Unblocking gas passages in valves.....	4
8	Release of gas by loosening or removal of the receptacle valve	5
8.1	Receptacle and valve enclosed inside coffin or jacket (gas contained).....	5
8.2	Valve end of receptacle enclosed (gas contained).....	6
8.3	Receptacle valve loosened (gas released to atmosphere)	6
8.4	Receptacle contents cooled by external refrigeration and inoperable valve exchanged (gas contained).....	7
8.5	Receptacle contents cooled by flash cooling and inoperable valve exchanged (gas released to atmosphere)	7
9	Release of gas by creation of additional vent in receptacle valve or receptacle body	8
9.1	Drilling on axis of valve outlet (gas contained).....	8
9.2	Drilling into valve body, valve end of receptacle enclosed (gas contained).....	9
9.3	Drilling into valve body (gas contained).....	9
9.4	Sawing into receptacle valve shank (gas released to atmosphere).....	10
9.5	Drilling into receptacle body (gas contained)	11
	APPENDIX	12

1 Introduction

Gas receptacle valves can become blocked by corrosion and foreign material, or made inoperable due to external or internal damage. When this happens, there is a tendency for receptacles to be put to one side and left for long periods of time. If left, such receptacles can become a potentially serious hazard. It is an essential safety requirement that such receptacles are dealt with without delay – the difficult operation of safely releasing the trapped residual gas must be carried out, the receptacle emptied, purged and made safe. It is recommended that Gas Suppliers are prepared with both equipment and trained personnel for dealing with such receptacles.

It has to must be used in conjunction with, industrial and medical gases including chemical gases.

2 Scope and purpose

This document is intended for suppliers of industrial, medical and specialty gas receptacles and details the procedures for the safe disposal of receptacles with blocked or inoperable valves.

It sets out practical techniques which have been tried and tested over some years within the Gas Industry. It must be used in conjunction with, the Code of Practice for the Disposal of Gases. (Ref. IGC Document 30/03).

The techniques described should only be followed by those who already have a good working knowledge of gas receptacle maintenance and who are fully trained in handling a wide range of industrial and medical gases including specialty gases.

3 Definitions

Chemical gases: gases produced by chemical synthesis. Receptacles are as defined by the UN Recommendations. They comprise cylinders, tubes, cryogenic receptacles (up to 1000 litres and bundles of cylinders).

4 Why receptacle valves become inoperable

Receptacle valves can become either blocked or inoperable in the open or closed position. The reasons are usually one of the following:

4.1 Internal corrosion

Internal corrosion may prevent the operation of the valve where the valve operating mechanism is constructed from materials that are prone to corrosion by the environment or the gas. Many corrosive gases are hygroscopic, i.e. absorb water from the atmosphere, and if gas users fail to purge valve outlets properly before and after use, highly corrosive conditions can occur inside the valve. If the valve operating mechanism is in contact with this corrosive material, seizure can occur.

4.2 Mechanical failure

This may be directly resulting from internal corrosion as per 4 above (e.g. seizure of the valve operating mechanism followed by breakage due to attempts to overcome the seizure).

Mechanical failures can also occur as a result of material or construction faults, excessive wear in the valve's moving parts, impact damage and weaknesses in the valve design or because the operator has forced the valve closed by applying too much tightening torque. In some valve designs the spindle can be operated without lifting the valve sealing device. Therefore a full receptacle can appear empty but the valve sealing device may suddenly lift and release gas.

4.3 Blockages

Blockage of a receptacle valve is normally due to one or more of the following materials entering the valve and compacting at the point where there is minimal cross section in the gas passage:

- Debris from inside the receptacle – examples include: PTFE thread tape, shot and grit remaining from receptacle cleaning operations, rust/corrosion production/millscale from receptacle walls.
- Debris compacted into the valve during filling – examples include: Swarf, PTFE thread tape, grit and dirt, purifier bed packings such as alumina and molecular sieve.
- Decomposition or other reaction products of the gas – examples include:
 - ethylene oxide polymer,
 - metal and silicon oxides which can result from their gaseous hydrides, e.g. phosphine and silane, coming into contact with air,
 - various reaction products that can result if the user permits feedback of reactive materials into the receptacle or receptacle valve,
 - metal halides which can result from reaction of halogens with the receptacle or valve material, e.g. ferrous and ferric chloride can be produced from the action of wet hydrogen chloride on steel.
- Valve seat material – valves fitted with a soft seat may become blocked by extrusion of the soft valve seat into the gas passage.
- Valve outlet connection cap seal – this can cause a blockage to the valve outlet when the connection cap seal has been extruded into it.
- Restricted flow orifice – restricted orifice screwed inside the valve outlet connection can be easily blocked because of the small diameter, typically 0.5 mm.

5 Precautions when releasing gas from receptacles with blocked or inoperable valves

5.1 Personnel safety and training

Operations to depressurize receptacles with blocked or inoperable valves must only be undertaken by trained and experienced technicians operating in accordance with the fundamental safe practices for handling gas receptacles.

Technicians who undertake this work must also have:

- A formal training in the IGC Code of Practice for Disposal of Gases.
- A good understanding of the properties of the receptacle content and the necessary precautions to be taken.
- A good practical understanding of the receptacle valve and the method of fitment to the receptacle.
- A practical knowledge of action to be taken in the event of an emergency situation developing.

A second person should be in the work area during all operations involving the depressurization of receptacles with blocked or inoperable valves.

Proper precautions must be taken in the work area to protect personnel from gas and particle discharges.

Appropriate personal protection equipment must be worn and emergency equipment must be readily available.

5.2 Equipment

All equipment must be designed (where appropriate) to withstand the maximum anticipated pressure and must comply with relevant statutory requirements relating to pressure vessels or systems.

The equipment must also be compatible with the gas(es) with which it will be used:

- for oxygen (in excess of 25 volume percent) and an other oxidants (some of which have a higher oxidising potential than oxygen), the system must be constructed of compatible materials free from flammable materials and cleaned in accordance with the IGC DOC 33/97. For certain very powerful oxidants (such as fluorine) pre-passivation of the equipment may be necessary.
- for flammable and pyrophoric gases, the system must be purged and free from air and oxidants.
- for corrosive gases, the system must be constructed from compatible materials and dried before use.

5.3 Facilities

Operations to depressurize receptacles with blocked or inoperable valves should be carried out in a responsible manner to ensure no hazardous conditions are created and that the environment is not harmed. Subsequent disposal of gases should be in accordance with the IGC Code of Practice for the Disposal of Gases:

- for flammable gases released to atmospheres, ignition sources should be excluded.
- for flammable gases contained in a system for subsequent disposal, the system must be purged and free from air and other oxidants to avoid the build up of explosive flammable gas/air or oxidant mixtures.
- for toxic gases, forced draft ventilation is preferred.

6 Introduction to depressurization techniques

6.1 Summary of techniques

There are three basic techniques for release of gas from receptacles with blocked or inoperable valves:

- unconventional operation of the receptacle valve.
- loosening or removal of the receptacle valve.
- creation of an additional vent in the receptacle valve or receptacle body.

Application of the above techniques will result in one of two modes of receptacle depressurization:

- where the gas remains contained until disposed of.
- Where the gas is released to atmosphere.

6.2 Choice of technique

Examples are provided to illustrate the principles of the techniques.

Where practicable, methods which contain the gas (for subsequent disposal) should be chosen for flammable or toxic gases. Where it is necessary to use techniques which release such gases to atmosphere, the work should be carried out in a well-ventilated area or under a fume hood/inside a fume cabinet.

In the event of doubt, or the absence of identification of the receptacle content, the selected method must make it possible to deal with all possible hazards.

7 Release of gas by unconventional operation of the receptacle valve

7.1 Partial stripping of the valve to facilitate movement of a broken spindle

Application: Gland packed valves fitted with a solid one-piece spindle where the spindle has sheared, limited to valves where the gland nut is independent of the spindle thread.

See Appendix drawing 1.

Typical example:

Procedure:

- The receptacle is secured to prevent toppling.
- Removal of the gland nut and packing will often reveal a sufficient part of the spindle to enable a wrench to be fitted. Penetrating oil can be sparingly applied (except in the case of oxygen and oxidants) and left to penetrate around the spindle operating threads. The auxiliary valve is fitted to the receptacle valve outlet and opened.
- The broken valve spindle is then gripped with a suitable wrench and the valve is opened. Gas will escape from the valve outlet (through the auxiliary valve) and from around the spindle. The packing and gland nut is replaced. The auxiliary valve is closed. Subsequent disposal of the gas is in accordance with the IGC Code of Practice for Disposal of Gases.

Key safety points:

- Do not attempt unless a sectioned drawing and/or example of the valve is available. There must also be a good understanding of its arrangement and operation.
- Wear appropriate safety equipment.
- When removing the gland nut, ensure that the valve spindle does not rotate with it.
- When the gland nut is removed, take care not to unscrew the valve spindle completely from the valve body.
- Beware of possibility of sudden gas release, and ejected valve parts/particulate matter.
- Care must be taken when using penetrating oil. Oil must not be used on valves in oxygen or oxidant service.
- This technique involves some gas discharge to atmosphere. Consider carrying out work involving toxic gases under forced ventilation. The gas released should be disposed of in accordance with the IGC Code of Practice for Disposal of Gases.
- Before removing the valve from the receptacle, ensure the valve port or opening is clear of obstruction by blowing nitrogen or air through the opening into the receptacle and observing the free passage in and out.

NOTE— the above (5.1) is given as a typical example. A similar approach may be adopted for other valve designs provided a sectioned drawing is available and a careful study has revealed that the proposed operation will not endanger the operator.

7.2 Unblocking gas passages in valves

Application: Any valve, containing pressure of maximum 10 bar. Also applicable to valve outlets only containing higher pressure but where the valve can be closed.

Equipment: Stiff thin steel wire, chemical solution, pressurized nitrogen supply.

Typical procedures: The receptacle is secured to prevent toppling. Blocked valves are normally very difficult to “unblock”.

A gas passage can sometimes be cleared by the careful use of a length of stiff wire and/or chemical solution compatible with the gas. Alternatively it may be possible to clear the blockage by careful use of a pressurized nitrogen supply connected to the valve outlet. Sudden pressure pulses are most likely to succeed. Do not over pressurize the cylinder.

Key safety points:

- Wear appropriate safety equipment.
- Particulate matter may be discharged at high velocity from the valve outlet.
- Extreme caution must be exercised when dealing with powerful oxidising or corrosive gases.
- Consider carrying out work involving toxic gases under forced ventilation.
- Care must be taken to avoid over pressurization of receptacles and valves when using high pressure nitrogen. Pressure regulation is essential in the nitrogen supply where the available nitrogen pressure exceeds the safe working pressure of the receptacle and valve.
- Before removing the valve from the receptacles, ensure the valve port or opening is clear of obstruction by blowing nitrogen or air through the opening into the receptacle and observing free passage in and out.

8 Release of gas by loosening or removal of the receptacle valve

8.1 Receptacle and valve enclosed inside coffin or jacket (gas contained)

See Appendix drawing 2.

Application: All gases (except acetylene)

Typical arrangement:

Procedure: There must be a documented operating procedure applicable to the design of coffin being used and the gas contained. Generally the following applies:

- The receptacle is inserted into the coffin and secured if necessary.
- The devalving head is fitted to the valve.
- The end plate/motor drive or hand wrench is fitted.
- Where necessary the system is pressurized to ensure absence of leaks, and/or purged of air and moisture.
- The receptacle valve is loosened or removed to permit gas discharge by opening valve A.

Key safety points:

- The coffin must be constructed from materials compatible with the gas to be contained. Special care must be taken in selecting materials for highly oxidising gases.
- The coffin must be capable of withstanding the resultant pressure after release of gas from the receptacle.
- Gas coffins are pressure vessels and must be designed and periodically tested to conform to relevant legislation.
- For flammable gases, the coffin must be freed from air. This can be done by evacuation and/or purging with an inert gas such as nitrogen, either through valve A or through additional connections.
- For oxygen (in excess of 25 volume percent) and oxidants, the coffin, gaskets and external surface of the receptacle and valve must be compatible, degreased and dried. (Ref. IGC Technical Note TN38-84R).
- For corrosive gases, the system must be dry.
- For toxic gases, the system must be pressurized and leak tested prior to operation.
- Subsequent disposal of the waste gas should be in accordance with the IGC Code of Practice for Disposal of Gases.
- After use, the coffin must be purged and free from all contaminants.
- Before opening the coffin, ensure the pressure has been released by blowing nitrogen or air through valve A into the coffin and observing free passage in and out.

8.2 Valve end of receptacle enclosed (gas contained)

See Appendix drawing 3.

Application: All gases, except acetylene.

Typical arrangement:

Procedure: The receptacle is secured firmly into the frame. The devalving head is fitted to the valve and the gas tight cap is secured. Where necessary the system is pressurized to ensure absence of leaks and purged either through valve A or through additional connections. The receptacle valve is loosened to permit gas discharge through valve A.

Key safety points:

- The equipment must be constructed from materials compatible with the gas to be contained. Special care must be taken in selecting materials for highly oxidising gases.
- The receptacle neck ring must be secure and in good condition in order to obtain a gas tight seal on its surface.
- The cap/mechanical securing system must be periodically inspected and capable of withstanding the resultant pressure and force after release of gas from the receptacle. Local statutory requirements relating to pressure testing must be complied with.
- For flammable gases, the cap must be freed from air. This can be done by evacuation and/or purging with an inert gas such as nitrogen.
- For oxygen (in excess of 25 volume percent) and oxidants, the cap, gaskets and receptacle valve must be compatible, degreased and dried. (Ref. IGC Technical Note TN38-84R).
- For toxic gases, the system must be pressurized and leak tested prior to operation.
- For corrosive gases, the system must be dry.
- Subsequent disposal of the waste gas should be in accordance with the IGC Code of Practice for Disposal of Gases.
- Before removing the gas tight cap, ensure the pressure is released by blowing nitrogen or air through valve A into the cap and observing free passage in and out.

8.3 Receptacle valve loosened (gas released to atmosphere)

See Appendix drawing 4.

Application: Gases that can be disposed of safely when released.

Typical arrangement:

Procedure:

- The receptacle is secured to prevent toppling and the valve restrainer is clamped to the receptacle and adjusted to give a safe clearance to prevent ejection of the valve. The lock nut is tightened. The valve is carefully loosened up to the restrainer and the gas allowed to escape.
- It may be necessary to change the valve restrainer adjustment in order to achieve the required gas discharge rate.

Key safety points:

- The restrainer should be of robust construction, capable of being firmly clamped to the receptacle.
- Wear appropriate safety equipment.
- Consideration should be given to the installation of an appropriate screen between the receptacle valve and the operator.

- For toxic or flammable gases, the procedure should be carried out in a well-ventilated area, fume hood or fume cubicle.
- Beware of sudden gas release.
- Disposal of the gas released should be in accordance with the IGC Code of Practice for Disposal of Gases.
- Before completely removing the valve from the receptacle, ensure the receptacle is depressurised.

8.4 Receptacle contents cooled by external refrigeration and inoperable valve exchanged (gas contained)

Application: Gases (except pyrophoric gases or acetylene) that can be positively identified and be cooled to below their boiling point. Receptacles that can be cooled without embrittlement occurring (ref. page 19).

Procedure:

- The receptacle is evenly cooled in a controlled manner to just below the boiling point of its content. The cooling method used is dependent on the required temperature.
- When the desired cooling has been achieved the receptacle is secured to prevent toppling, the faulty valve is carefully loosened, removed and replaced with a serviceable valve to a reduced torque.
- While the receptacle is warming to ambient temperature, the valve is tightened if gas leakage is observed. The content is immediately transferred to another receptacle or disposed of in accordance with the IGC Code of Practice for Disposal of Gases.

Key safety points:

- Due account must be taken of the physical properties of the receptacle content to ensure it will fully condense at the proposed refrigeration temperature. Special consideration is necessary when dealing with gas mixtures whose composition may change as cooling takes place.
- Cooling should be evenly distributed to avoid excessive temperature gradients across the receptacle.
- Receptacles should not be cooled to below their minimum temperature. This is particularly important with steels where permanent embrittlement may occur. Advice on the minimum temperature for any particular receptacle should be sought from a metallurgist. In the absence of metallurgical advice, the following minimum temperatures must be observed:
 - Normalised steel receptacles and quenched and tempered steel receptacles manufactured after 1950: -50 °C.
 - Other steel receptacles: -25 °C.

(Aluminium alloy receptacles do not suffer loss of impact resistance due to low or very low temperatures).

- Care should be taken when handling cold receptacles. They must not be dropped or handled violently. Receptacles with loosened valves should not be moved if they contain gas.
- Cooling operations involving the use of gaseous coolants should only be undertaken in well-ventilated areas and operators must be made aware of the risks of asphyxiation.
- Wear appropriate safety equipment which includes protection against cold burns.
- For flammable gases, special precautions may be necessary as air may enter the receptacle during the valve exchange operation.
- For toxic gases, valve exchange should be carried out in a well-ventilated area, fume hood or fume cubicle.
- Disposal of the gas released should be in accordance with the IGC Code of Practice for Disposal of Gases.

8.5 Receptacle contents cooled by flash cooling and inoperable valve exchanged (gas released to atmosphere)

See Appendix drawing 5.

Application: Low pressure liquefiable gases that can be positively identified and safely discharged. This method has been successfully used for large diameter, thin-walled receptacles of anhydrous ammonia.

Typical arrangements:

Procedure: The receptacle is held in a vice with the valve uppermost. The valve is loosened, usually one to one and a half turns is sufficient. The remote valve removal tool is then fitted to the valve and valve removal is completed from a safe distance. The gas discharge rate will reduce rapidly as the surface of the liquid in the receptacle cools. A new valve is fitted as soon as the gas discharge rate permits it.

Key safety points:

- This method can only be used in well-ventilated remote locations away from personnel.
- Wear appropriate safety equipment.
- Care should be taken as liquefied gas may eject from the receptacle, particularly if the receptacle is full, is of small diameter or is thick-walled.
- The valve must be removed from a safe distance.

9 Release of gas by creation of additional vent in receptacle valve or receptacle body

9.1 Drilling on axis of valve outlet (gas contained)

See Appendix drawing 6.

Application: Valves whose designs permit destruction of the seat by drilling on the axis of the valve outlet. Gases except powerful oxidants and acetylene.

Typical arrangement:

Procedure: The receptacle is secured to prevent toppling and the drilling adaptor is fitted to the valve outlet using an appropriate gasket. Where necessary the system is pressurized to ensure absence of leaks and purged. The drill is rotated slowly until a gas path across the valve seat is obtained. If leakage occurs around the drill, the gland nut is tightened. Gas is discharged by opening valve A.

Key safety points:

- The equipment must be constructed from materials that are compatible with the gas to be contained.
- Wear appropriate safety equipment.
- A sectional drawing and/or example of the valve should be available to enable the operator to drill into the gas path.
- The largest practicable drill diameter compatible with the valve outlet union should be used to minimise the risk of breakage.
- Special care should be taken if the receptacle is fitted with a dip tube and contains a liquefied gas.
- The drill should be fitted with a collar to prevent its ejection under pressure.
- A mark should be made on the visible part of the drill to avoid excessive entry into the valve body.
- For flammable gases, the system must be freed from air. This can be done by evacuation and/or purging with an inert gas such as nitrogen.
- For oxygen (in excess of 25 volume percent) and oxidants, all components must be compatible and degreased. (Ref. IGC Technical Note TN38-84R). The drilling must proceed very slowly to avoid risk of hot spots. This method is not suitable for powerful oxidants.
- For toxic gases, the system must be pressurized and leak tested prior to operation.
- Subsequent disposal of waste gas should be in accordance with the IGC Code of Practice for Disposal of Gases.

- Before removing the valve from the receptacle, ensure the valve port or opening is clear of obstruction by blowing nitrogen or air through the opening into the receptacle – observing the free passage in and out.

9.2 Drilling into valve body, valve end of receptacle enclosed (gas contained)

See Appendix drawing 7.

Application: All valves. Gases except powerful oxidants and acetylene.

Typical arrangement:

Procedure:

- The receptacle is secured to prevent toppling and the receptacle neck ring is cleaned. The cap/drilling adaptor and gasket are fitted. The restraining device (to prevent ejection of the cap under pressure) is fitted (see 6.2.). The centre punch is inserted through the drilling adaptor (drill, gland packing and gland nut removed) and the drilling position is marked on the valve body. The centre punch is removed. The drill, gland packing and gland nut is assembled.
- Where necessary the system is pressurized to ensure absence of leaks and purged either through valve A or through additional connections.
- The drill is rotated slowly until a gas path through the valve body is obtained. If leakage occurs around the drill, the gland nut is tightened.
- The gas is discharged through valve A.

Key safety points:

- Equipment must be constructed from materials that are compatible with the gas to be contained.
- A sectioned drawing and/or example of the valve should be available to enable the operator to drill into the gas path.
- Wear appropriate safety equipment.
- The largest practicable drill diameter should be used to minimise the risk of breakage.
- The cap/securing system must be periodically inspected and capable of withstanding the resultant pressure and force after release of gas from the receptacle. Local statutory requirements relating to pressure testing must be complied with.
- The receptacle neck ring must be secure and in good condition in order to obtain a gas tight seal on its surface.
- Special care should be taken if the receptacle is fitted with a dip tube and contains liquefied gas. It is recommended that the receptacle is positioned to avoid liquid entering the cap.
- The drill should be fitted with a collar to prevent its ejection under pressure.
- A guide mark should be made on the visible part of the drill to avoid excessive entry into the valve body.
- For flammable gases, the system must be freed from air. This can be done by evacuation and/or purging with an inert gas such as nitrogen.
- For oxygen (in excess of 25 volume percent) and oxidants, all components must be compatible and degreased. (Ref. IGC Technical Note TN38-84R). The drilling must proceed very slowly to avoid risk of hot spots. The method is not suitable for powerful oxidants.
- For toxic gases, the system must be pressurized and leak tested prior to operation.
- Subsequent disposal of waste gas should be in accordance with the IGC Code of Practice for Disposal of Gases.
- Before removing the valve from the receptacle, ensure the opening made by drilling is clear of obstruction by blowing nitrogen or air through the port or opening into the receptacle and observing the free passage in and out.

9.3 Drilling into valve body (gas contained)

See Appendix drawing 8.

Application: Gases except powerful oxidants and acetylene.

Typical arrangement:

Procedure:

- The receptacle is secured to prevent toppling and the outlet sealed with a plug or cap nut. The drilling adaptor is secured to the valve body either by drilling and tapping into the valve body or by clamping.
- Where necessary the system is pressurized and leak tested prior to operation.
- The drill is rotated slowly until a gas path through the valve body is obtained. If leakage occurs around the drill, the gland nut is tightened.
- The gas is discharged through valve A.

Key safety points:

- Equipment must be constructed from materials that are compatible with the gas to be contained.
- A sectioned drawing and/or example of the valve should be available to enable the operator to drill into the gas path.
- When drilling and tapping, care must be taken to select a part of the valve body with sufficient material to machine the drilling adaptor thread without breaking through into the gas path. There must be sufficient thread engagement to withstand the receptacle pressure.
- The largest practicable drill diameter should be used to minimise the risk of breakage.
- The drill should be fitted with a collar to prevent its ejection under pressure.
- A guide mark should be made on the visible part of the drill to avoid excessive entry into the valve body.
- Special care should be taken if the receptacle is fitted with a dip tube and contains a liquefied gas.
- Wear appropriate safety equipment.
- For flammable gases, the system must be freed from air. This can be done by evacuation and/or purging with an inert gas such as nitrogen.
- For oxygen (in excess of 25 volume percent) and oxidants, all components must be compatible and degreased. (Ref. IGC Technical Note TN38-84R). The drilling must proceed very slowly to avoid the risk of hot spots. The method is not suitable for powerful oxidants.
- For toxic gases, the system must be pressurized to ensure absence of leaks.
- Subsequent disposal of waste gas should be in accordance with the IGC Code of Practice for Disposal of Gases.
- Before removing the valve from the receptacle, ensure the opening made by drilling is clear of obstruction by blowing nitrogen or air through the opening and observing the free passage in and out.

9.4 Sawing into receptacle valve shank (gas released to atmosphere)

Application: Gases, except powerful oxidants, acetylene and pyrophoric gases, that can be disposed of safely when released.

Typical procedure:

- The receptacle should be properly secured in a convenient position.
- A sawcut is made into the valve shank at a point that is convenient and which offers the minimum depth of cut to the gas path. The cut is made using a handsaw fitted with a thin fine-toothed blade. Careful use of the saw will enable a small flow of gas to be achieved at the point of the break through into the gas path.
- For flammable gases, a water spray may be used to cool the cut and minimise the risk of sparking.

Key safety points:

- A sectioned drawing and/or example of the valve should be available to enable the operator to cut into the gas path. Some valves do not have concentric bores in their shanks.
- It should be noted that sawing into the valve weakens its mechanical properties.
- Wear appropriate safety equipment.

- Beware of possibility of sudden gas release and ejected particulate matter.
- Special care should be taken if the receptacle is fitted with a dip tube and contains liquefied gas. The receptacle should be positioned such that the tube end is in the vapour space.
- For oxygen (in excess of 25 volume percent) and oxidants, the valve body and saw must be free from dirt and grease. Sawing must proceed very slowly to avoid risk of hot spots. This method is not suitable for powerful oxidants or pyrophoric gases.
- For toxic or flammable gases, the procedure must be carried out in a well-ventilated area, fume hood or fume cubicle.
- Disposal of the gas released should be in accordance with the IGC Code of Practice for Disposal of Gases.
- Before removing the valve from the receptacle, ensure the opening made by the cut is clear of obstruction by blowing nitrogen or air through the opening and observing the free passage in and out.

9.5 Drilling into receptacle body (gas contained)

See Appendix drawing 9.

Application: All gases except acetylene and powerful oxidants. Receptacles with a low working pressure (less than 20 bar) or receptacles with a higher working pressure when their diameter does not exceed 80 mm.

Typical arrangement:

Procedure:

- The receptacle should be properly secured in a convenient position.
- The drilling adaptor is secured to the receptacle wall. Various methods of securing can be used including a belt and heavy steel jaws mounted to a frame in which the receptacle is inserted.
- Where necessary the system is pressurized and leak tested prior to operation.
- The drill is rotated until a gas path through the receptacle wall is obtained. If leakage occurs around the drill, the gland nut is tightened.
- The gas is discharged through valve A.

Key safety points:

- When dealing with receptacles at higher pressures than 20 bar, it should be noted that only limited experience is available in the industry. The operator should only use this method if he is confident that the receptacle wall is in good condition and that drilling the hole will not impair the overall safety of the receptacle.
- Equipment must be constructed from materials that are compatible with the gas to be contained.
- The drill diameter should not be too small to minimise the risk of breakage and not too large to minimise the risk of receptacle rupture. A diameter of between 3mm and 5mm is recommended.
- The drill should be fitted with a collar to prevent its ejection under pressure.
- Special care should be taken with liquefiable gases. Drill into the vapour space.
- For flammable gases, the system must be freed from air. This can be done by evacuation and/or purging with an inert gas such as nitrogen.
- For oxygen (in excess of 25 volume percent) and oxidants, all components must be compatible and degreased, (including gaskets) and the drilling must proceed very slowly to avoid risk of hot spots. Drilling chips may be hot enough to trigger a dangerous reaction with oxidants. The method is not suitable for powerful oxidants.
- For toxic gases, the system must be pressurized and leak tested prior to operation.
- Subsequent disposal of waste gas should be in accordance with the IGC Code of Practice for Disposal of Gases.
- Before removing the valve from the receptacle, ensure the opening made by drilling is clear of obstruction by blowing nitrogen or air through the opening into the receptacle and observing the free passage in and out.
- The receptacle must be destroyed after it has been emptied and purged.

APPENDIX

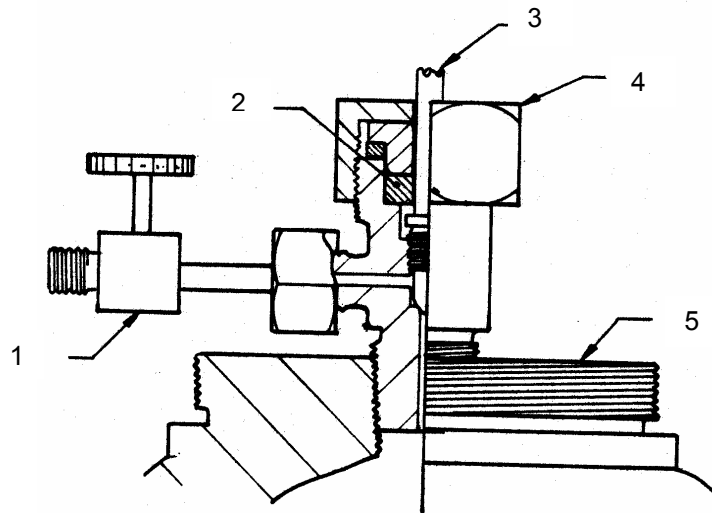

- 1 - Auxiliary valve
- 2 - Gland packing
- 3 - Broken valve spindle
- 4 - Gland nut
- 5 - Receptacle

Drawing 1: Partial stripping of the valve to facilitate movement of a broken spindle

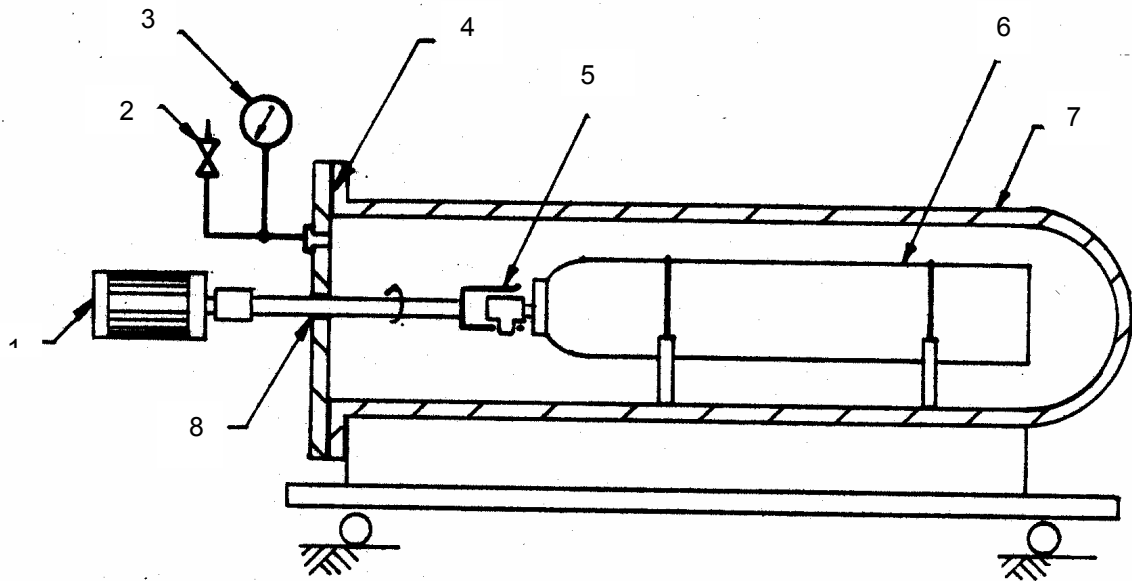

- 1 - Motor drive (or hand wrench)
- 2 - Valve A
- 3 - Pressure gauge
- 4 - Gasket
- 5 - Devalving head
- 6 - Receptacle
- 7 - Receptacle
- 8 - Coffin

Drawing 2: Receptacle and valve enclosed inside coffin or jacket (gas contained)

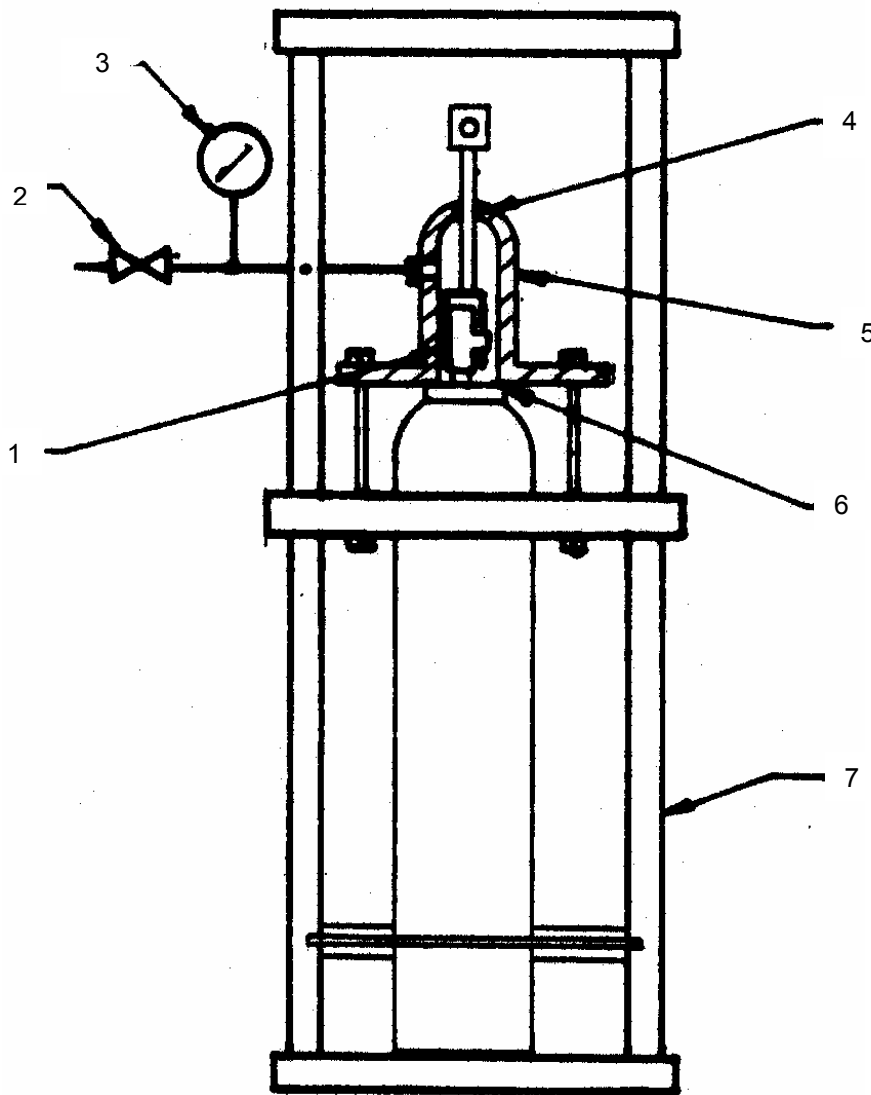

- 1 - Devalving head
- 2 - Valve A
- 3 - Pressure gauge
- 4 - Gas tight gland
- 5 - Gas tight cap
- 6 - Gasket
- 7 - Receptacle securing frame

Drawing 3: Valve end of receptacle enclosed (gas contained)

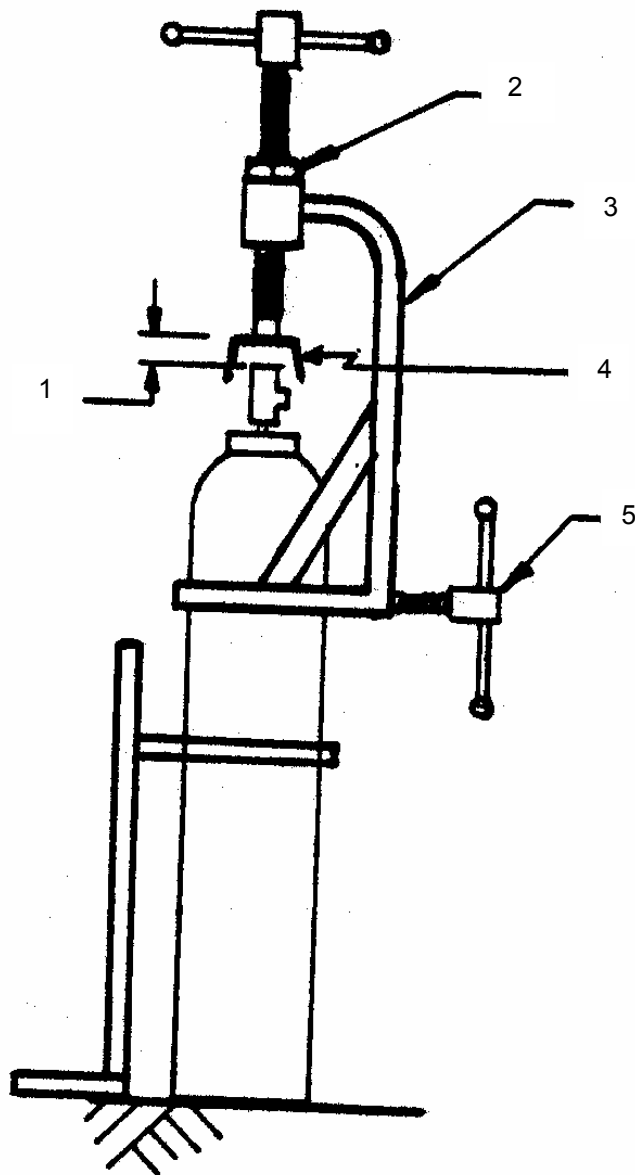

- 1 - Screw to required clearance
- 2 - Lock-nut
- 3 - Valve restainer
- 4 - Retrainer cup
- 5 - Screw to clamp to receptacle

Drawing 4: Receptacle valve loosened (gas released to atmosphere)

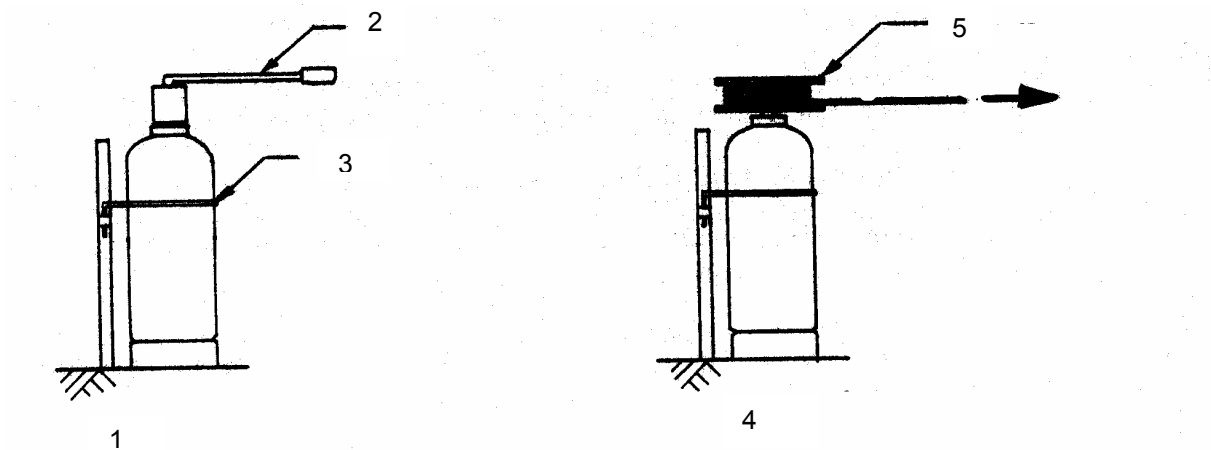

- 1 - Technician "loosens" valve using a wrench
- 2 - Wrench
- 3 - Clamp
- 4 - Technician pulls rope from a safe place to complete the removal of receptacle valve
- 5 - Drum with circa 15m of rope. Centre has clamp to fit receptacle valve

**Drawing 5: Receptacle contents cooled by flash cooling and inoperable valve exchanged
(gas released to atmosphere)**

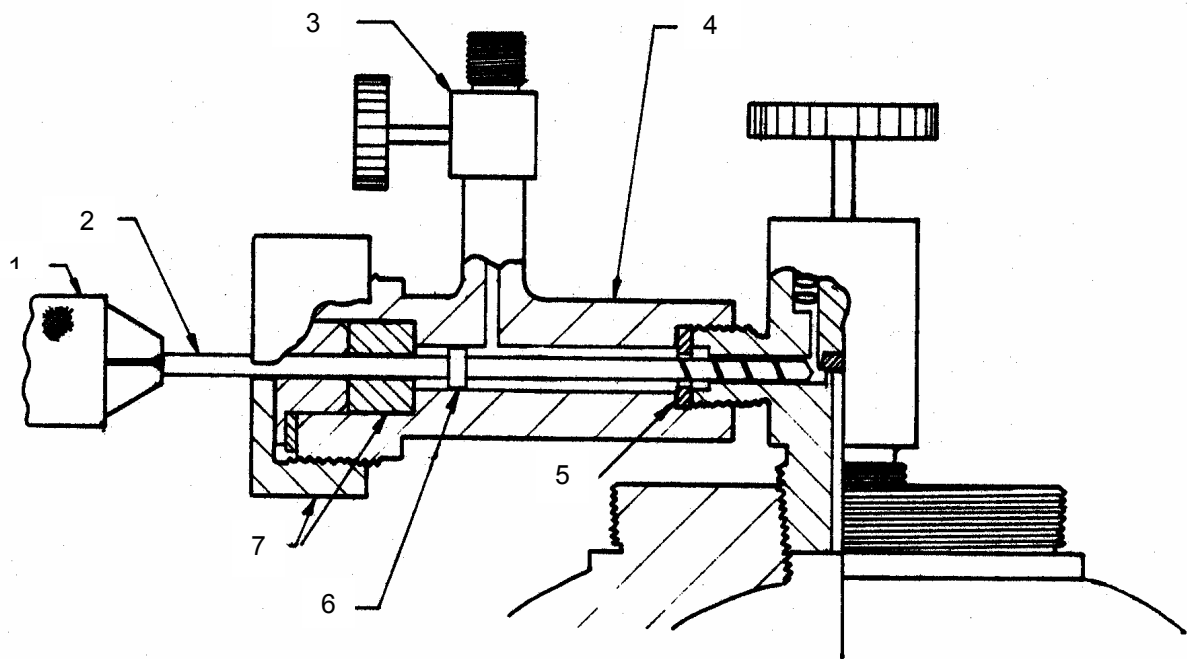

- 1 - Hand drill
- 2 - Drill
- 3 - Valve A
- 4 - Drilling adaptor
- 5 - Gasket
- 6 - Retaining collar
- 7 - Gland packing and gland nut (around drill)

Drawing 6: Drilling on axis of valve outlet (gas contained)

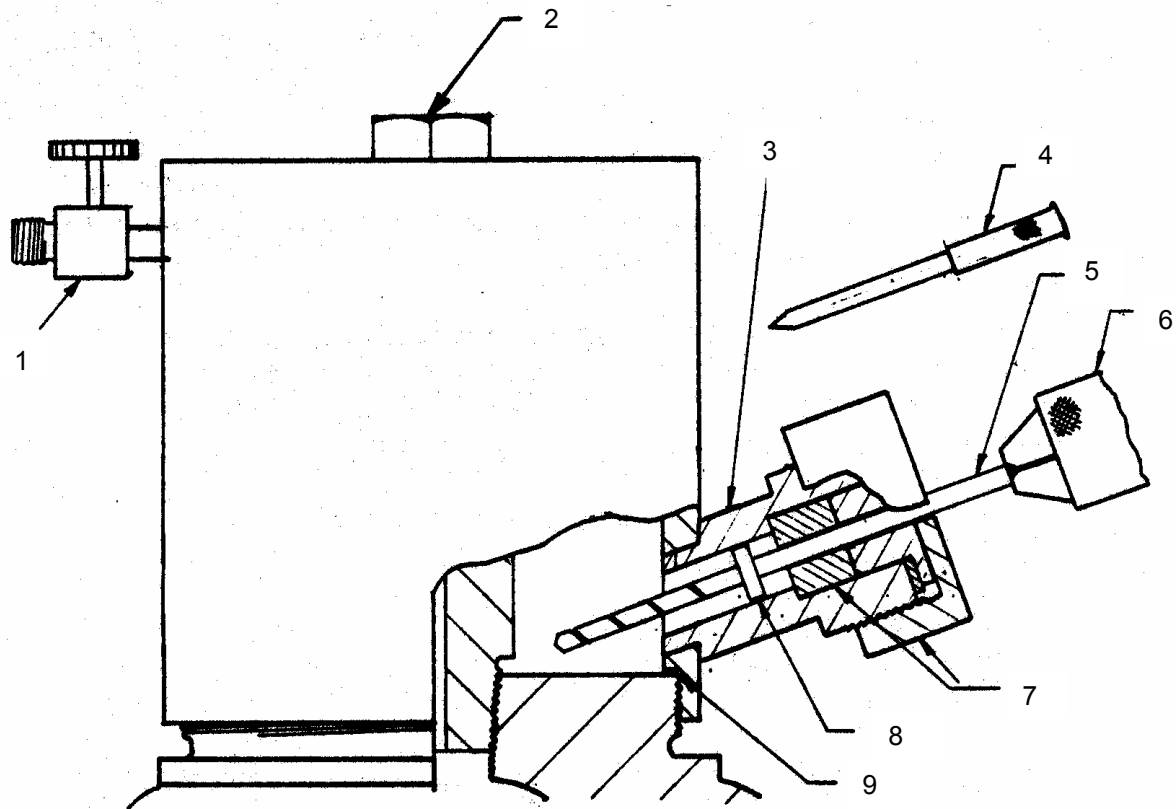

- 1 - Valve A
- 2 - Cap held by restraining device
- 3 - Drilling adaptor
- 4 - Centre punch
- 5 - Drill
- 6 - Hand drill
- 7 - Gland packing and gland nut (around drill)
- 8 - Retaining collar
- 9 - Gasket

Drawing 7: Drilling into valve body, valve end of receptacle enclosed (gas receptacle)

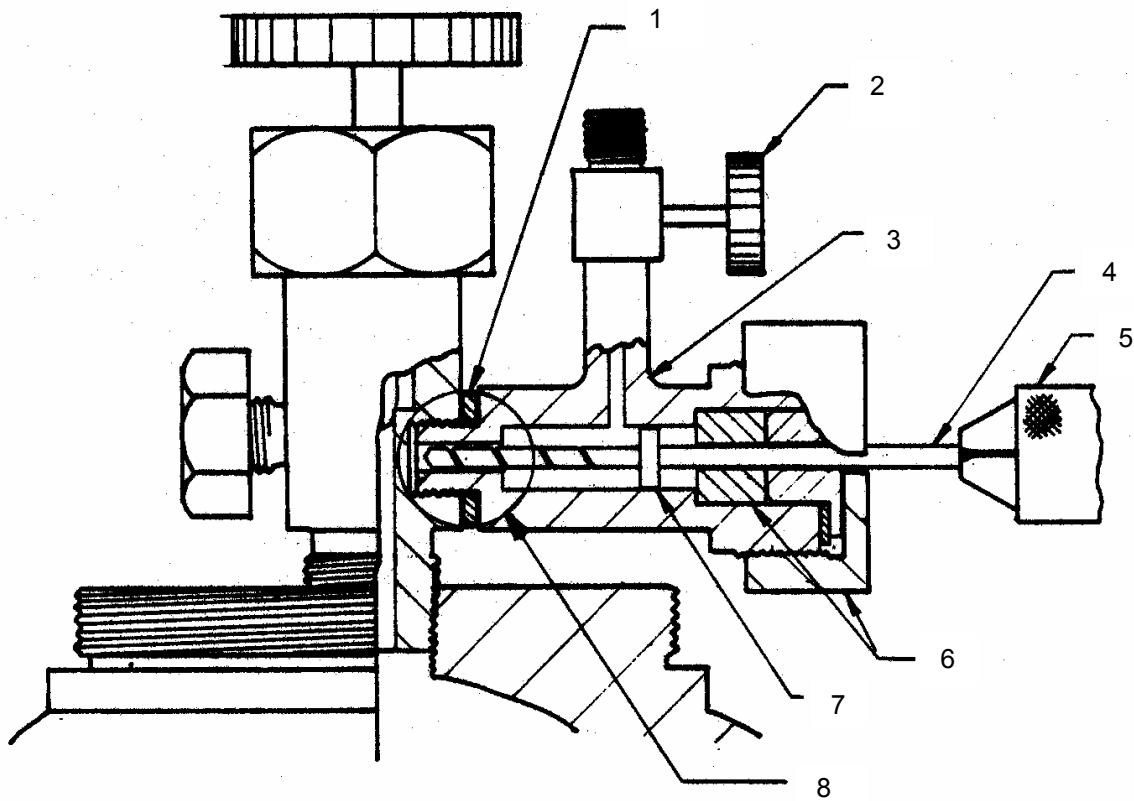

- 1 - Gasket
- 2 - Valve A
- 3 - Drilling adaptor
- 4 - Drill
- 5 - Hand drill
- 6 - Gland packing and gland nut (around drill)
- 7 - Retraining collar
- 8 - Drilling adaptor threaded into or clamped onto valve body

Drawing 8: Drilling into valve body (gas contained)

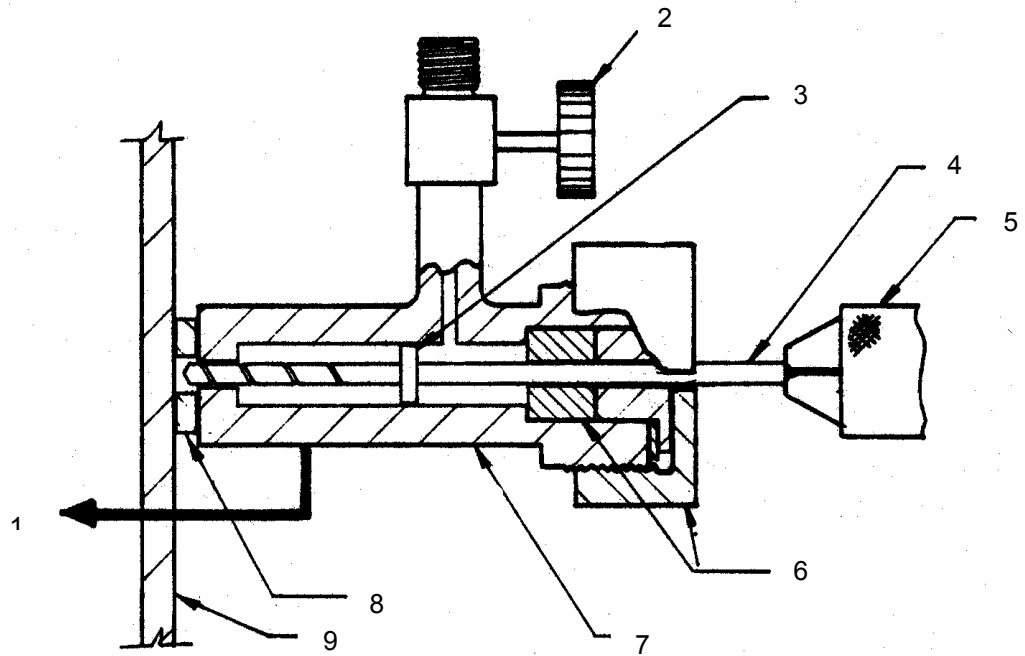

- 1 - Device to firmly clamp drilling adaptor to receptacle wall
- 2 - Valve A
- 3 - Retaining collar
- 4 - Drill
- 5 - Drill chuck
- 6 - Gland packing and gland nut (around drill)
- 7 - Drilling adaptor
- 8 - Gasket
- 9 - Receptacle wall

Drawing 9: Drilling into receptacle body (gas contained)